



# QC400

Automatic control unit for three/single-phase motors  
with digital or mechanical limits





---

## DESCRIPTION

The QC400 has been designed to operate an industrial door safely under electrical control of a pushbutton or key switch. Its intended use is to be connected to a suitable motor not exceeding the load for the controller. Connections are provided for mains supply (both 3ph and 1ph), motor power, mechanical or electronic limits, Push Buttons, Pneumatic or Electrical or Optical Safety Edge, Photo beam safety and 24VDC Auxiliary power (100mA max). Optional plug-in connectors for Radio and Traffic light. Basic functions include: - Stop, Open, Close, and Auto close via a time delay provided a suitable monitored safety edge is fitted.

## IMPORTANT SAFETY INSTRUCTIONS

**These instructions contain important information on the installation and the use of the QC400 unit. Please keep them even after installation. Do not start installing the QC400 unit without having first read these instructions. The installation can be made only by a qualified technician. In order to respect the rules in force, the installation must include an automatic cut off switch with minimum distance between the contacts of at least 3mm. The safety of the control unit depends on a correct installation. Be at a reasonable distance from shutter/awnings in movement. Check frequently if any loss of balance, sign of wear or damages wires are shown. Do not use if any repairing or maintenance is needed. GAPOSA declines all responsibility in case of improper use of the product or of an incorrect installation.**

**WARNING: it is very important for the people's safety to follow strictly these instructions.**

**IMPORTANT: Stay at distance while the shutter is in movement.**

**IMPORTANT: Frequently check whether any cable disconnects, wears out or any damage happens. Do not use the control unit in case a reparation or a maintenance job is required.**

**KEEP THIS INSTRUCTIONS.**

Warning: it is highly recommended to activate the impulsive mode only after having completed the set-up and adjustments of the control unit. In particular, during the mechanical limit switches adjustment, select always the dead-man operation mode. During the encoder limit switches set-up the control unit will only allow the dead-man working mode.

## DIRECTIVES

2014/35/UE 2014/30/CE 2014/53/CE 2006/42/CE

---

EN 61000-6-2:2005 EN 61000-6-3:2007 + A1:2011

---

EN 60950-1:2006 + A1:2010 + A2:2013 +A11:2009 + A12:2011

---

EN 13241-1:2004 + A1:2011 EN 13849-1:2015

---

EN 12453:2017 EN 12978:2003 + A1:2009

---

EN 301489-1:2008 EN 301489-3:2002

---

EN 300220-2:2007 EN 13241-1:2004 + A1:2011

---

## TECHNICAL DETAILS

Installation	Vertical on a vibration free and flat wall
Temperature range (operating)	-10...+50°C
Humidity	Up to 93% RH non-condensing.
Vibration	Low-vibration installation, wall mounted.
Supply voltage: <b>(Selectable by jumper using terminal 'X1')</b>	3ph - 230/400V~ ± 10% L1,L2,L3,PE ('N' required ONLY for services - see par. 7/9) 1~ 230V~ ± 10% L1,N,PE 50/60Hz, Mains fuse max: 3 x 10A
Transformer	Max 10 VA , VDE 0570/EN61558 Secondary winding is overload protected by fuses.
Motor output	Max motor load by 3 x 400VAC: 2.2 kW Max motor load by 3 x 230VAC: 1.3 kW Max motor load by 1 x 230VAC: 0.75 kW
Emergency stop, Stop and safety jumper.	Function as normal stop command and disconnect power to contactor coil.
24VDC Output (terminals X6-8,9):	24VDC ± 20% (non-regulated), Max load: 100mA
Safety edge input: (X5-3,4)	PNE/air switch Electric type - 8k2 termination ± 10% Optical type (Fraba OSE or Dalmatic TSS/RSS) Performance level C, Category 2
Optical safety edge: (X5-5,6,7)	Input voltage high (green): 2.5 - 5.0 Volt. Input voltage low (green): < 0.5 Volt. Input frequency range (green): 250 - 2000 Hz. (50% duty-cycle) Pulse interval maximum (green): 7.0 mS (when not 50% duty-cycle)
Photo input: (X6-9,10,11,12)	Photo, 24 VDC (e.g. self contain photo cell) Performance level C, Category 2
Electronic limits	RS485, Data+ Data-, terminated with 120 Ohm. Designed for Dalmatic encoder, Feig encoder and Kostal encoder (self setting)
Mechanical limits	Plug-in connector X7 for mechanical switches.
AUX solid-state relay output (X5-1,2):	NO output. Max 30V - Max 50 mA.
Box dimension	305 x 210 x 120 mm

## SOFTWARE SETTINGS

Reversetime (Photo, Open) = 0.50 sec.	Force control (DIP5 = ON) Force control set points = 4+4
Reversetime (safety edge) = 0.25/0.1/0.05 sec.	Force control delay (before measuring) = 0.8 sec.
Auto close time (Factory setup15 sec.) = 1 - 240 sec. (adaptive)	Force control frequency range = 60 - 240 Hz (900 - 3600 RPM with 4 pulses/rotation)
Runtimer = 120 sec.	Stop by force (DIP6=OFF/ON) = -2.5/-1.0 %
Electronic afterrun with monitoring (DIP4 = ON) = 0.3 sec.	Wear limit (from initial values) (DIP6=OFF/ON) = 6/5%
Min. Pullbacktime by photo, edge and force reversing (by DIP1 and DIP2 = OFF) = 0.1 sec.	Automatic update of set points (force control) = 0.3%/10 Door cycles
Opening counts, service interval = 1000 counts	
Reset time, Service LED (active elec. Counter) = 240 sec.	
Time delay before position failure (encoder is not moving) = 4.0 sec.	
Dw fail afterrun = 0.5 sec.	
<b>AUX 1 setting: ON when door is stopped.</b>	

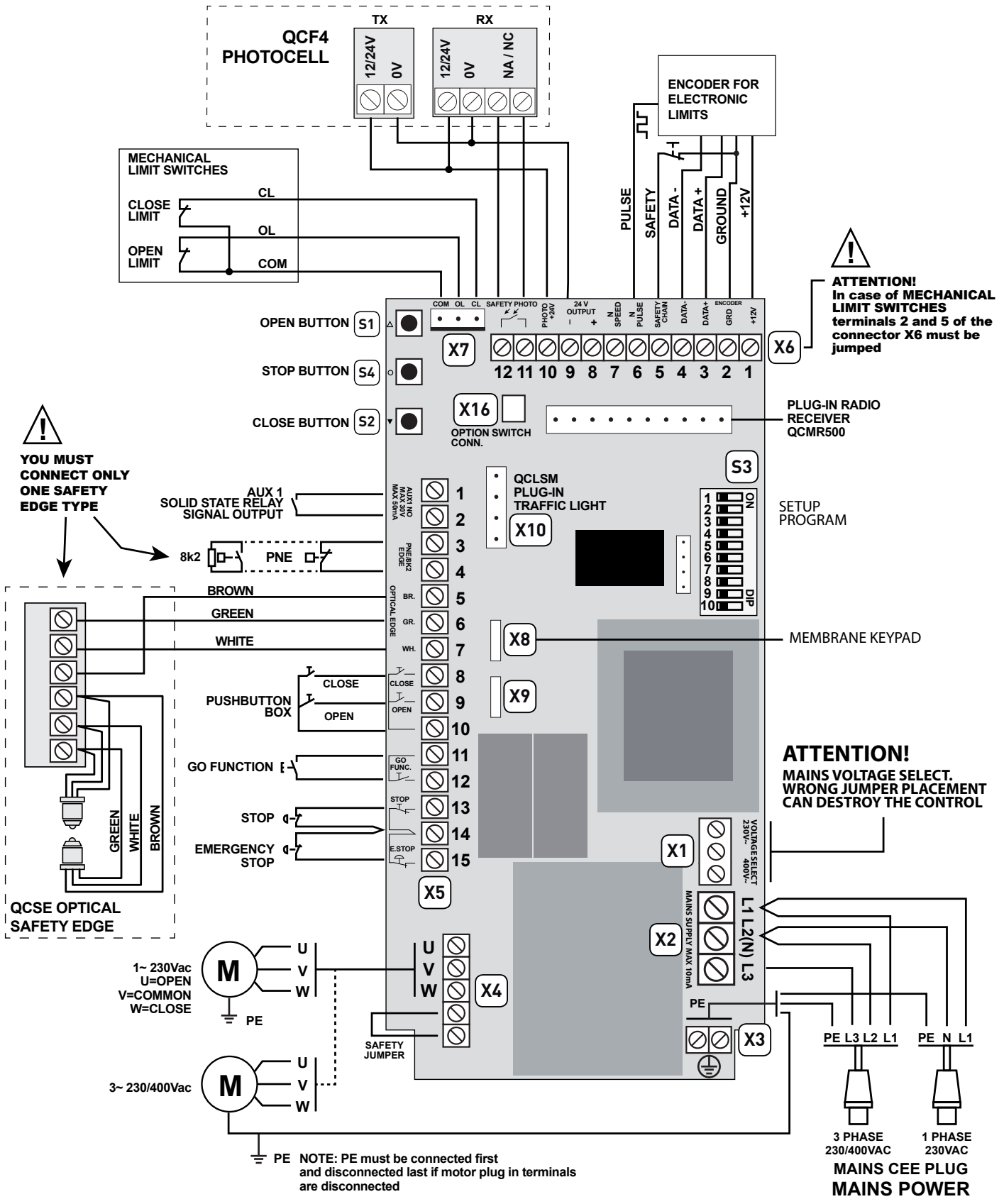

**ATTENTION!**  
In case of MECHANICAL LIMIT SWITCHES terminals 2 and 5 of the connector X6 must be jumped

**YOU MUST CONNECT ONLY ONE SAFETY EDGE TYPE**

**ATTENTION!**  
MAINS VOLTAGE SELECT. WRONG JUMPER PLACEMENT CAN DESTROY THE CONTROL

1~ 230Vac  
U=OPEN  
V=COMMON  
W=CLOSE

3~ 230/400Vac

NOTE: PE must be connected first and disconnected last if motor plug in terminals are disconnected

3 PHASE 230/400VAC  
1 PHASE 230VAC  
**MAINS CEE PLUG  
MAINS POWER**

# 1 INSTALLATION

For a correct installation:

- Install where the control unit can be protected from rain or adverse weather conditions
- Mounting must be vertical
- The mounting surface must be flat and not be subject to vibrations
- Do not install in an area of potential risk of condensation
- It is important that the door can be clearly seen from the position of the control while operating
- Install in an area not accessible to children or unauthorized persons
- Do not perform any electrical connections before the installation is completely accomplished

## 2 ELECTRICAL OPERATING INSTRUCTIONS

Read carefully and respect the connection's sequence. **IMPORTANT!** All the connection operations must be performed only after the main power supply has been disconnected. **TURN OFF THE MAIN POWER SWITCH BEFORE ANY OTHER OPERATION!**

When connecting control to mains supply a mains isolator switch (16A CEE - plug) according EN 12453 is required. The supply disconnect device (main switch or CEE plug) must be installed between 0.6 m and 1.7 m above floor level.

### 2.1 CONTROL UNIT POWER SUPPLY

The control unit can be powered in three different modes: 400V~ 3-phase, 230~ 3-phase or 230V~ 1-phase.

**WARNING!** The installation must include an automatic cut off switch with minimum distance between the contacts of at least 3 mm.

**WARNING:** The power supply of the motor and of the control unit must be the same. Otherwise you can damage the motor and the control unit and put at risk the safety of the installer.

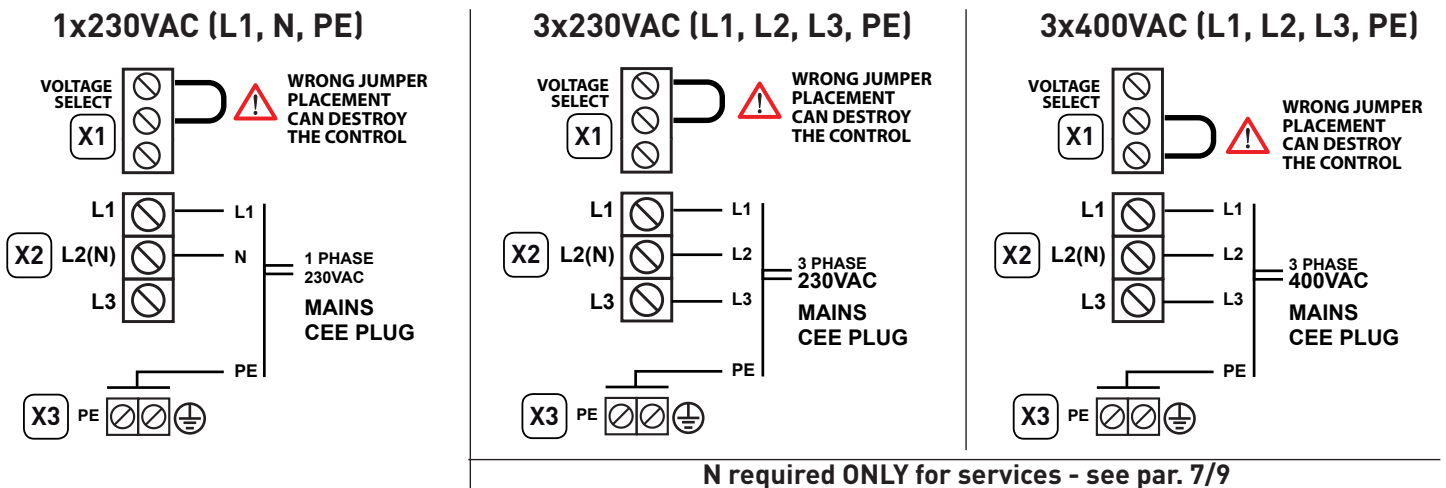

If you need to disconnect the power cable and then to reconnect it or change the control unit wiring sequence, you **HAVE TO** connect the wires properly, restoring the original configuration. Take care to connect the ground wire to the X3 terminal. **WARNING!** Verify the direction of rotation of the motor supplied with 3ph x 400V or 1ph x 230V: pay attention to the direction of rotation of the motor: by pressing the OPEN button (S1) the door has to open while, by pressing the CLOSE button (S2), the door must close. In case of wrong direction, reverse two of the phases (L1, L2 and L3) on the X2 terminal or U (OPEN) and W (CLOSE) on X4 terminal.

### 2.2 CONNECTING THE CONTROL UNIT TO THE MOTOR

After the motor and control are fitted they can be connected with a plug-in cable.

The cable has plugs on each end for an easy fitting.

The plugs for motor and control panel are different and cannot be interchanged.

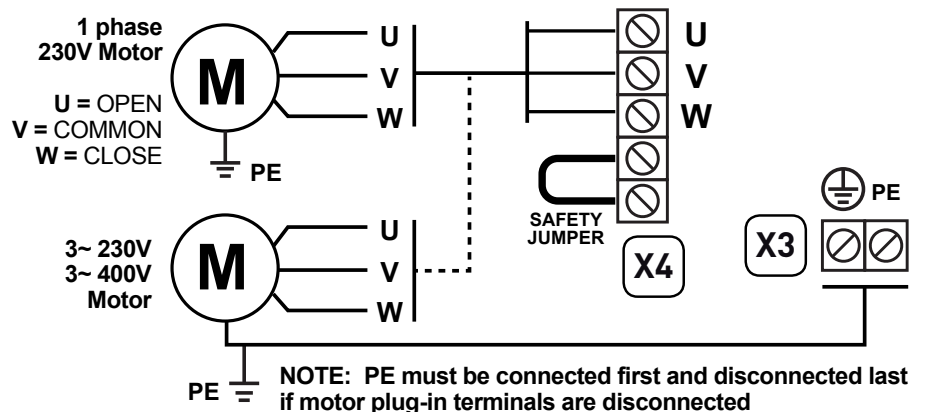

### 3 DIPSWITCH FUNCTIONS

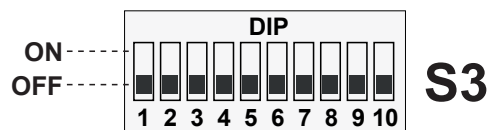

NOTE	OPERATING LOGIC	DIP									
		1	2	3	4	5	6	7	8	9	10
<b>A</b>	Dead-man OPEN/CLOSE	OFF	OFF	-	-	-	-	-	-	-	-
<b>B</b>	Impulse OPEN/CLOSE	ON	ON	-	-	-	-	-	-	-	-
<b>C</b>	Impulse OPEN / Deadman CLOSE	ON	OFF	-	-	-	-	-	-	-	-
<b>OPTIONS</b>											
<b>D</b>	Auto close (after delay time)	ON	ON	ON	-	-	-	-	-	-	-
<b>E</b>	Electronic after run / edge monitoring	-	-	-	ON	-	-	-	-	-	-
<b>F</b>	Force control (Multiturn) (NOT AVAILABLE AT THE MOMENT)	-	-	-	-	ON	-	-	-	-	-
	Force control fine sense (NOT AVAILABLE AT THE MOMENT)	-	-	-	-	-	ON	-	-	-	-
<b>G</b>	Go Function Standard	-	ON	-	-	-	-	OFF	-	-	-
	Go Function Special (Start/Stop, radio)	-	ON	-	-	-	-	ON	-	-	-
	Edge super fast reverse 0.05 sec (NOT AVAILABLE AT THE MOMENT)	-	-	-	-	-	-	-	ON	-	-
	Edge reverse time – Normal (NOT AVAILABLE AT THE MOMENT)	-	-	-	-	-	-	-	OFF	ON	-
<b>LIMIT SWITCH TYPE SELECTION</b>											
	Mechanical limit switch	-	-	-	-	-	-	-	-	-	OFF
	Electronic encoded limit switch	-	-	-	-	-	-	-	-	-	ON

NOTE	SAFETY LOGIC
<b>A</b>	When an obstacle is detected during the DOWN operation the movement is stopped with a brief upward movement; It has no effect on the way UP.
<b>B</b>	When an obstacle is detected during the UP operation It has no effect. During the DOWN operation the movement is reversed until the opening limit switch.
<b>C</b>	When an obstacle is detected during the UP operation It has no effect. During the DOWN operation the movement is reversed until the opening limit switch
<b>D</b>	<b>This function can only be selected when DIP2 is in ON position and safeties are connected.</b> The auto closing time is preset to 15 Sec. To reset a new time setting, run the door to open position and push both open and close buttons for minimum 5 Sec. When the red LED START flashing, release the buttons. After that wait until the new desired auto closing time and then push the close button. Max auto closing time is about 4 min. If max setting time is exceeded, the red LED STOP flashing and the auto close time is adjusted back to 15 Sec. Auto closing time is remembered after power OFF. Auto closing can also be disabled with a switch connected to X16 connector.
<b>E</b>	When DIP4 is in ON position, the edge monitoring is selected. When adjusting the limits, DIP4 is set to OFF. Close limit switch shall be adjusted such as the door is stopped 5 cm before the floor. After this change DIP4 to ON. (PNE edge only). Clearing fail is done by closing the door in dead-man mode (hold to run mode), keeping the close push-button ON until the door is stopped by signal from safety device.
<b>F</b>	Force control setting: Change DIP5 to ON position. (Fail LED and LED on membrane keypad showing long flash). The door shall be mounted and limits adjusted before activating the force control. With DIP5=ON the force control is automatic learned by the first 2 fully open cycles without stop, starting in closed position. The controller will work as a dead-man controller until all force values are learned. If the control only run by small step when closing – Tacho pulses is missing.
<b>G</b>	Special technical information - see par. 10

ADDITIONAL FEATURES	
<b>Photo</b>	Photo circuit is tested before every close operation. Photo circuit must be connected during the setting process.
<b>Service</b>	Service showing for every 1000 openings [see separate LED guidance]. Reset of service is done by activating the electronic counter and keeping this active for minimum 4 minutes. The controller will then automatic switch to normal operation with service LED out. The service function is only activating the service LED. (NOT AVAILABLE AT THE MOMENT)
<b>Safety</b>	The door cannot close when there is an error in the photo or safety edge. By a special code the door can close one time in hold to run mode. Press and hold STOP when pressing 222111 (2 = DOWN push button and 1 = OP push button). Code must be pressed within 6 sec

## 4 CONNECT QC400 TO MECHANICAL LIMIT SWITCH MOTOR

**ATTENTION:** if you connect a control unit already pre-set for mechanical limits to a motor with encoder limits, the motor won't work correctly. In particular, the motor will not find the limit positions and this could put at risk the safety of people and/or things.

In order to connect the QC400 with a motor with mechanical limits set the DIP10 on S3 in OFF (See 4.1 PROGRAMMING).

- |   |        |  |
|---|--------|--|
| 1 | GREY   | > OPEN LIMIT SWITCH                          |
| 2 | GREEN  | > OPEN BUTTON (Micro on motor limit switch)  |
| 3 | WHITE  | > SAFETY                                     |
| 4 | YELLOW | > CLOSE BUTTON (Micro on motor limit switch) |
| 5 | PINK   | > CLOSE LIMIT SWITCH                         |
| 6 | BROWN  | > SAFETY                                     |

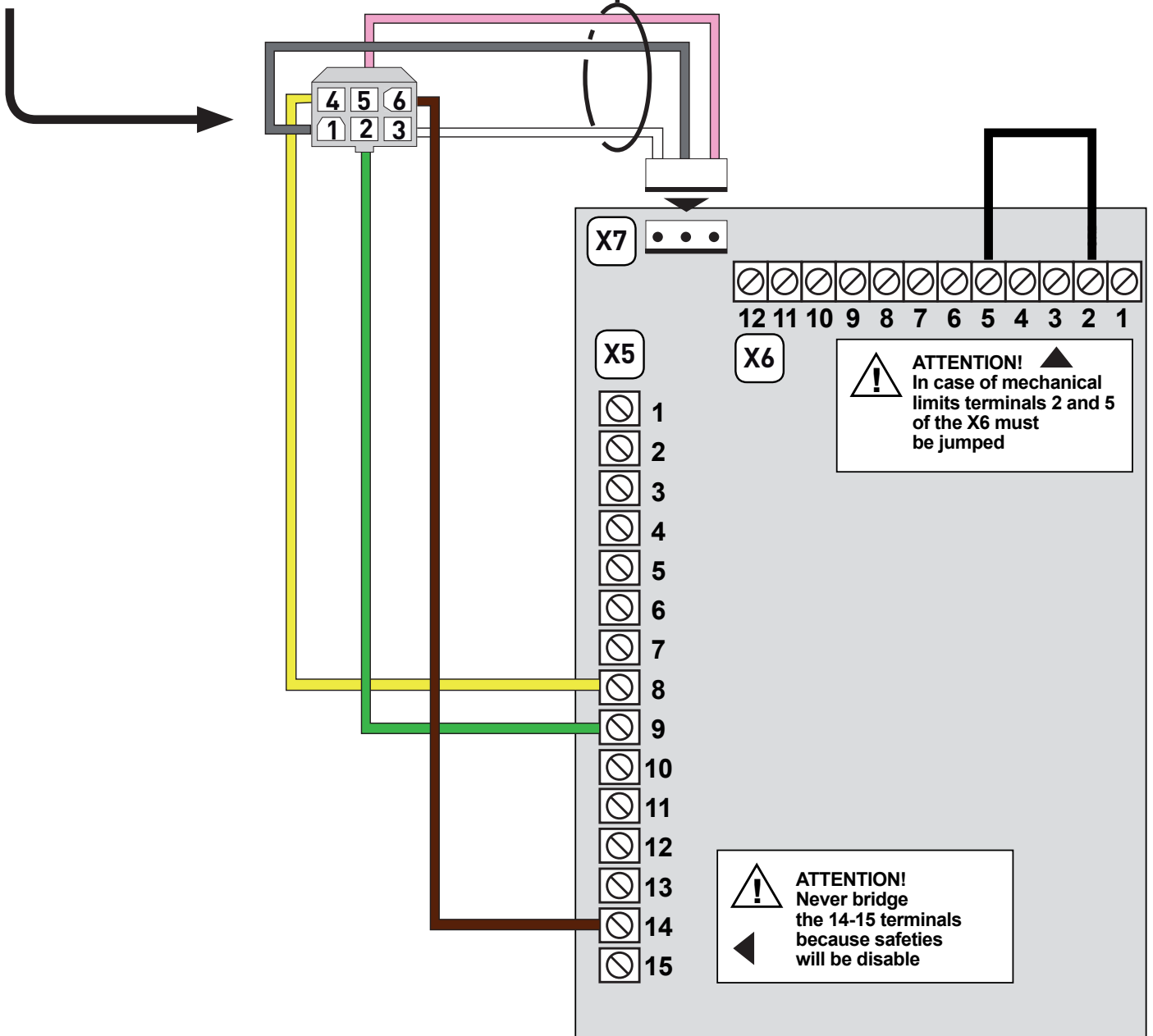



## 4.1 PROGRAMMING WITH MECHANICAL LIMIT SWITCH

**ATTENTION:** to let the safeties work, these must be connected **before** starting the control unit setup.

### Setup process - Mechanical limits standard

1	Set DIP10 in OFF position for selecting mechanical limits and DIP1 and DIP2 to OFF position for deadman operation. Standard control for mechanical limits are for PNE edge type (3-4 terminals on X5) and no photo connected. <b>ATTENTION: Switching DIP10 to ON position and back to OFF will reset to mechanical standard with ONLY PNE edge type.</b>
2	Press OPEN or CLOSE to the desired close and open limit position and adjust cam until the limit is correct. Note: if door is moving in the wrong direction the 2 phases on the mains connection must be interchanged.
3	Limits are now adjusted. Check that the safety edge is working (if mounted).

### Setting process - Mechanical limits with other safety connected

**ATTENTION: additional safeties as OSE (connected to X5 5-6-7) or photocell (connected to X6 9-10-11-12) will be active only after the setting process**

4	Make setup process 1 and 2 and move the door away from close limit.
5	Connect the requested safeties. Activate setting by pressing OPEN+STOP for about 10 sec then release. The red LED FAIL (PCB) start with 2 short flashes
6	Press STOP to stop setting the edge type and photo. Yellow LED SPEED/SER confirming with 1 sec
7	Limits are now adjusted and edge type and photo circuit are memorised. Check that the safety functions are working as expected. <b>ATTENTION: moving DIP10 to ON position and back to OFF will reset to mechanical standard with ONLY PNE edge type.</b>

## 4.2 LED GUIDANCE

Yellow LED CONF./SER. (PCB)		Yellow LED STOP (PCB)		Green LED POWER (PCB)	
Fixed light	Service needed (open counts reached)	Fixed light	Stop activated or both limits are active	Fixed light	The controller is powered
1 sec. flash	Confirming learning process	1 long flash	Safety chain activated		
		2 long flashes	Photo – safety test failed.		
		3 long flashes	Safety edge – safety test failed.		
		4 long flashes	Stop circuit – safety test failed.		
		5 long flashes	Safety chain – safety test failed		
		6 long flashes	EEPROM failure. Elec. Counter or position counter by force control		
		7 long flashes	EEPROM failure. Powerup failure		
		8 long flashes	Welded contactor fail		
		9 long flashes	Internal watchdog timeout.		
		10 long flashes	Main processor crystal fail		
Red LED FAIL (PCB)				Red LED CIRCUIT ERROR (PCB)	
Fixed light	If Photo or Edge is activated when CLOSE pushbutton is activated			Fixed light	PCB circuit error fail
1 long flash	Auto close learning active				
2 short flashes	Limits, edge and photo not learned				
2 long flashes	Force control (speed) not learned				
3 long flashes	Door stopped by force control				
4 long flashes	Door stopped by runtime				
5 long flashes	Door stopped by force control wear				
6 long flashes	Tacho failure – pulses missing				
Continues long flashes	Fail state PNE edge monitoring. Check impuls by floor missing.				

## 5 QC400 CONNECT TO ELECTRONIC LIMIT SWITCHES MOTOR

**ATTENTION:** if you connect a control unit already pre-set for mechanical limits to a motor with encoder limits, the motor won't work correctly. In particular, the motor will not find the limit positions and this could put at risk the safety of people and/or things.

In order to connect the QC400 with a motor with electronic limit switch:

1. Remove the 3pins white terminal from the cable (our part # FLCE31W012 ) - Fig. 1
2. Peel the 3 wires and connect them as showed in FIG. 2
3. See 5.1 PROGRAMMING

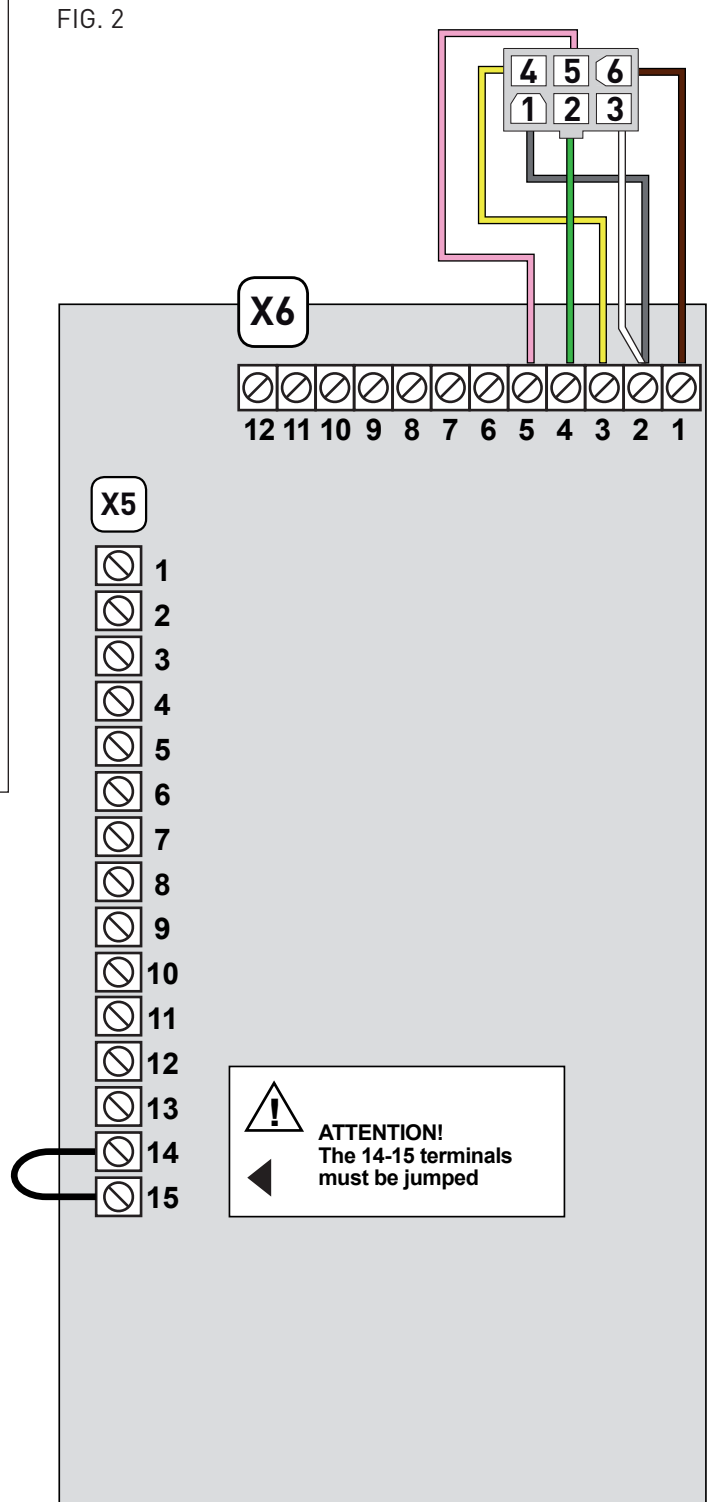
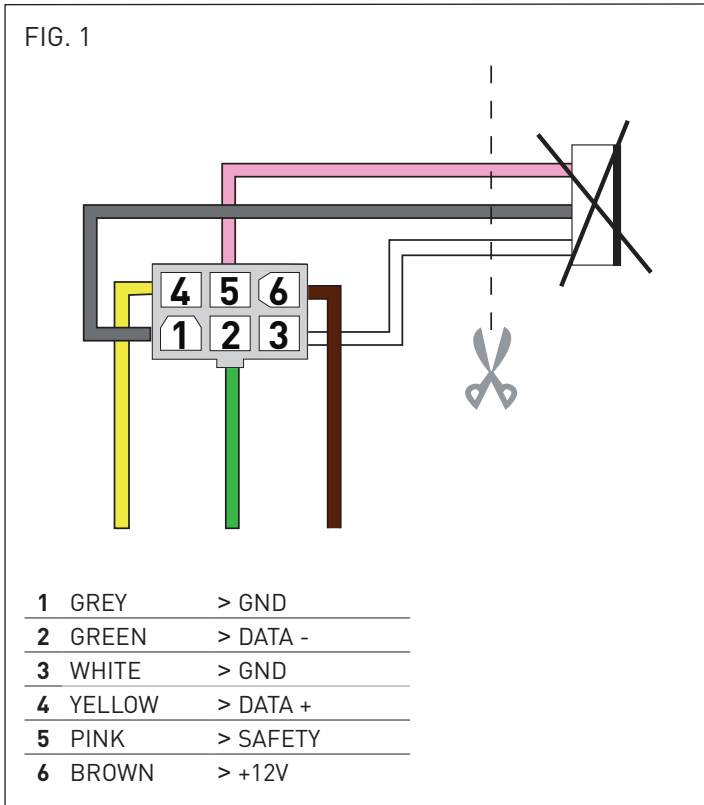

## 5.1 PROGRAMMING WITH ELECTRONIC LIMIT SWITCH

**ATTENTION:** to let the safeties work, these must be connected **before** starting the control unit setup.

Setting process	
1	Turn OFF the power and connect the encoder and all safety equipment. The controller memorises the encoder type by power-up.
2	Set DIP10 in ON position and turn the power ON. Activate setting by pressing OPEN + STOP for about 10 sec until the red LED FAIL (PCB) starts with 2 short flashes <b>ATTENTION: Switching DIP10 to ON position and back to OFF will reset to mechanical standard with ONLY PNE edge type.</b>
3	First press the CLOSE button to the desired down limit position. Note: if door is moving in the wrong direction the 2 phases on the mains connection must be interchanged. (Alternatively choose the special phases interchange function by pressing OPEN + STOP for 20 sec. - Yellow LED SPEED/SER confirming with 1 sec.)
4	Press STOP to set the down limit position. Yellow LED SPEED/SER confirming with 1 sec
5	Press OPEN to the desired UP limit position. By open position you can adjust the UP limit position finely by running OPEN and CLOSE, but first operation must be in OPEN direction for minimum 2 sec.
6	Press STOP button to save the UP limit position, encoder direction, <b>edge type and photo</b> Yellow LED SPEED/SER confirming with 1 sec
7	Limits are now adjusted and edge type and photo circuit are set. Check that the safety edge and photo functions are working as expected.

## 5.2 LED GUIDANCE

Yellow LED CONF./SER. (PCB)		Yellow LED STOP (PCB)		Green LED POWER (PCB)	
<b>Fixed light</b>	Service needed (open counts reached)	<b>Fixed light</b>	Stop activated or both limits are active	<b>Fixed light</b>	The controller is powered
<b>1 sec. flash</b>	Confirming setting process	<b>1 long flash</b>	Safety chain activated	<b>Red LED CIRCUIT ERROR (PCB)</b>	
<b>Red LED FAIL (PCB)</b>		<b>2 long flashes</b>	Photo – safety test failed.	<b>Fixed light</b>	PCB circuit error fail
<b>Fixed light</b>	If Photo or Edge is activated when CLOSE pushbutton is activated	<b>3 long flashes</b>	Safety edge – safety test failed.		
<b>1 short flashes</b>	No answer from encoder. Check RS485	<b>4 long flashes</b>	Stop circuit – safety test failed.		
<b>1 long flash</b>	Auto close setting active	<b>5 long flashes</b>	Safety chain – safety test failed		
<b>2 short flashes</b>	Limits, edge and photo not learned	<b>6 long flashes</b>	EEPROM failure. Elec. Counter or position counter by force control		
<b>2 long flashes</b>	Force control (speed) not learned	<b>7 long flashes</b>	EEPROM failure. Powerup failure		
<b>3 long flashes</b>	Door stopped by force control	<b>8 long flashes</b>	Welded contactor fail		
<b>4 short flashes</b>	Calculation failure (e.g. both limits the same)	<b>9 long flashes</b>	Internal watchdog timeout.		
<b>4 long flashes</b>	Door stopped by runtime	<b>10 long flashes</b>	Main processor crystal fail		
<b>5 long flashes</b>	Door stopped by force control wear				
<b>6 long flashes</b>	Tacho failure – pulses missing				
<b>7 short flashes</b>	Encoder position out of learned area. (Reset by power up or resetting)				
<b>8 short flashes</b>	Kostal encoder – Power failure.				
<b>Continues long flashes</b>	Fail state PNE edge monitoring. Check impuls by floor missing.				

## 6 BRAKE RELAY CONNECTIONS ON AUX 1

Brake can be used for both mechanical and electronic limits.

AUX1 output is going OFF 30 ms before motor contactor is turned ON for releasing the brake a brief time before motor starts.

AUX1 output is going ON 20 ms before motor contactor is turned OFF, for activating the brake a brief time before motor stops.

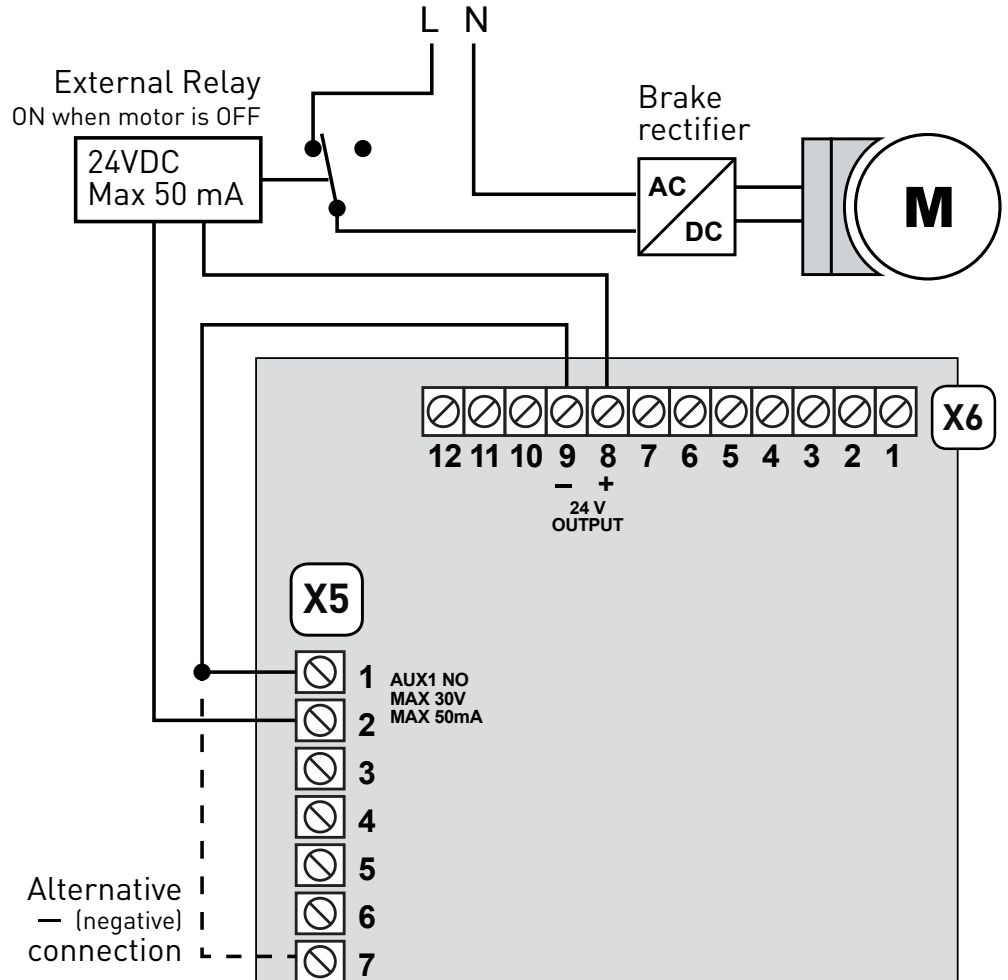

## 7 FLASHING LIGHT CONNECTIONS (only for 3phase power supply)

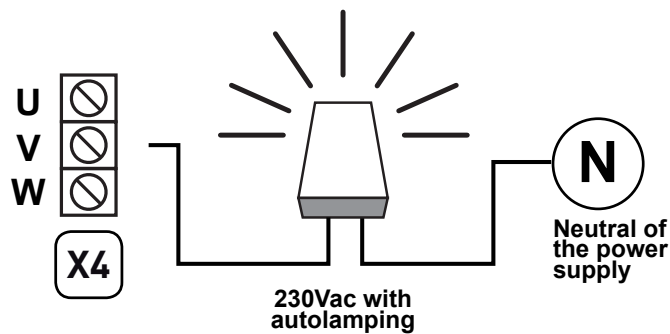

## 8 PLUG-IN RADIO RECEIVER QCMR500 (OPTIONAL)

The control can be radio operated thanks to the QCTE transmitter that allows the storage of 1997 radio codes. The QCTE transmitter must be matched to the QCMR500 radio receiver, already inserted into the related slot (see page 5). Set DIP7 in ON (GO Special functions - see par. 10).

Please look at the QCMR500 instructions to connect it to the control unit and to match it to the transmitter.

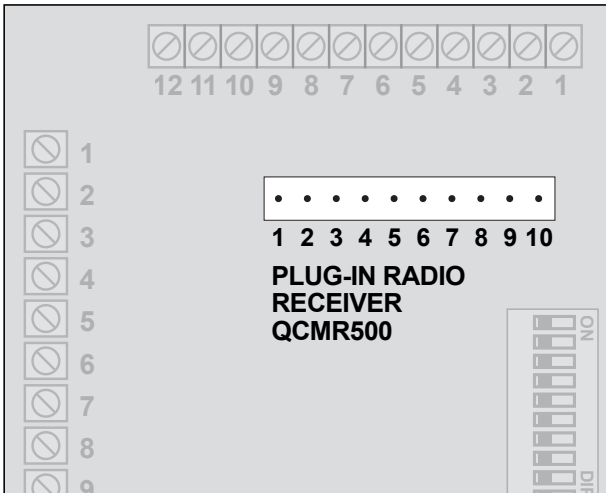

Radio plug-in terminals:

Pin 1 = output signal to board "Go function" (+24V)

Pin 2 = connected to board +24V after stop circuits

Pin 3 = Not connected.

Pin 4 = connected to board +24V after stop circuits

Pin 5 = connected to GND on board. (supply)

Pin 6 = connected to +24 power on board (supply)

Pin 7 - 10 = Not connected.

**NOTE: the entrance "GO" (terminals 11-12 on X5) follows the same logical of functioning selected for radio receiver.**

## 9 PLUG-IN TRAFFIC LIGHT QCLSM (OPTIONAL)

This is a plug-in board to be used with the QC400 in order to control flashing lights, courtesy lamps or traffic lights during the operation of the door or shutter.

Connect the QCLSM to X10. The possible operation options are described in the QCLSM instruction manual.

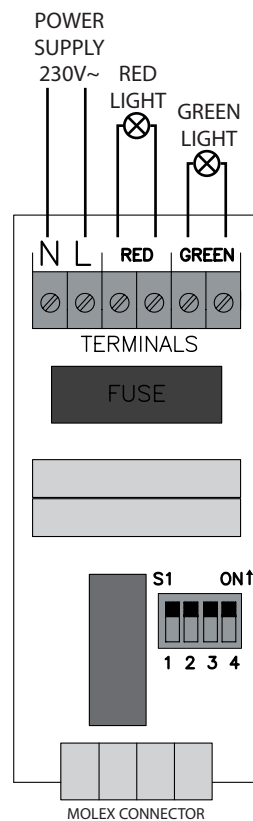

---

## 10 SPECIAL TECHNICAL INFORMATION

**Go Func normal:** Go function input terminal X5-11,12. (DIP7 OFF)

**Go function, when photo safety is connected to controller:**

When Door is not open → the door will open.  
When door is open → the door will start closing.  
When door is running down → the door will open.  
When door is running up → no change.

**Go function, when no photo safety is connected to controller:**

When Door is not open → the door will open.  
When door is open → no closing (for safety reason because no photo)  
When door is running down → the door will open.  
When door is running up → no change.

**Go Func special:** Go function input terminal X5-11,12. (DIP7 ON)

**Go function, when photo safety is connected to controller:**

When Door is not open or closed → the door will do opposite of last.  
When door is open → the door will start closing.  
When door is running down → the door will stop and next push opening.  
When door is running up → the door will stop and next push closing

**Go function, when no photo safety is connected to controller:**

The "go function special" is not active when no photo is connected. (safety)

**Photo disabling before the door reaches the floor level**

If you want to disable the photo safety function a little distance before close limit:

1. Move the door to the desired disabling point -
2. Activate the STOP button and then also the OPEN + CLOSE buttons for 5 sec. ( 3-double push)
3. Confirm LED will flash 1 sec.

Check that that the disabling point is correct.





**Gaposa** srl - via Ete, 90 - 63900 Fermo - Italy  
T. +39.0734.220701 - F. +39.0734.226389 - info@gaposa.com  
[www.gaposa.com](http://www.gaposa.com)