



Best fire-resistant gates

# MARC-P1D

## SINGLE-LEAF SLIDING GATE WITH EVACUATION DOOR

# ASSEMBLY MANUAL



Konarskie, ul. Kórnicka 4  
62-035 Kórnik

tel. +48 61 222 75 00  
fax +48 61 222 75 01  
biuro@malkowski.pl

## Contents

List of illustrations .....	Błąd! Nie zdefiniowano zakładki.
1. Introduction .....	Błąd! Nie zdefiniowano zakładki.
2. Information concerning revisions to the manual .....	Błąd! Nie zdefiniowano zakładki.
3. Related documents .....	Błąd! Nie zdefiniowano zakładki.
4. Preparation to the assembly work .....	Błąd! Nie zdefiniowano zakładki.
4.1. Building conditions .....	Błąd! Nie zdefiniowano zakładki.
4.2. Assembly documents .....	Błąd! Nie zdefiniowano zakładki.
4.3. Assembly tools .....	Błąd! Nie zdefiniowano zakładki.
4.4. Parts .....	Błąd! Nie zdefiniowano zakładki.
5. Fire-resistant sliding gate assembly stages .....	Błąd! Nie zdefiniowano zakładki.
5.1. Installing the front module .....	Błąd! Nie zdefiniowano zakładki.
5.2. Installing the guide rail .....	Błąd! Nie zdefiniowano zakładki.
5.3. Installing gate leaf panels .....	Błąd! Nie zdefiniowano zakładki.
5.4. Installing the wall-mounted gate stopper .....	Błąd! Nie zdefiniowano zakładki.
5.5. Installing the guide roller .....	Błąd! Nie zdefiniowano zakładki.
5.6. Installing the rope system and the ballast .....	Błąd! Nie zdefiniowano zakładki.
5.7. Installing the electromagnetic keeper .....	Błąd! Nie zdefiniowano zakładki.
5.8. Checking the gate leaf for closing properly .....	Błąd! Nie zdefiniowano zakładki.
5.9. Installing the covers .....	Błąd! Nie zdefiniowano zakładki.
5.9.1. <i>Installing the pocket - wall protective cover</i> .....	<i>Błąd! Nie zdefiniowano zakładki.</i>
5.9.2. <i>Installing the ballast cover (ballast at the gate leaf front face side)</i> .....	35
5.9.3. <i>Installing the ballast cover (ballast at the gate stopper side)</i> .....	37
5.9.4. <i>Installing the gate leaf's front face masking cover and its threshold masking covers</i>	<b>Błąd! Nie zdefiniowano zakładki.</b>
5.9.5. <i>Installing the lintel cover</i> .....	39
5.9.6. <i>Installing the guide rail cover</i> .....	<b>Błąd! Nie zdefiniowano zakładki.</b>
6. Installing the VIC drive .....	Błąd! Nie zdefiniowano zakładki.

# List of illustrations

FIGURE 1: OPERATION AREA OF THE GATE .....	7
FIGURE 2: LAYOUT OF GATE ASSEMBLY ELEMENTS.....	10
FIGURE 3: FRONT MODULE - BALLAST REMOVAL.....	11
FIGURE 4: FRONT MODULE - POSITION IN RELATION TO THE EDGE OF THE HOLE .....	12
FIGURE 5: FRONT MODULE - ASSEMBLY .....	13
FIGURE 6: FRONT MODULE - FIXING IT TO THE STEEL CONSTRUCTION .....	13
FIGURE 7: COMPLETING THE GUIDE RAIL LENGTH.....	15
FIGURE 8: INSTALLING THE FIRST GUIDE RAIL LENGTH.....	16
FIGURE 9: INSTALLATION GUIDE RAIL DEPENDING ON LINTEL MATERIAL .....	17
FIGURE 10: INSTALLING THE GUIDE RAIL CONNECTOR .....	18
FIGURE 11: INSTALLING THE NEXT GUIDE RAIL LENGTHS .....	19
FIGURE 12: REMOVING THE PROTECTIVE FILM FROM THE PANEL SURFACE .....	20
FIGURE 13: ORIENTATION OF THE FRONT FACE PANEL IN RELATION TO THE FRONT MODULE .....	21
FIGURE 14: PLACING THE FRONT FACE PANEL IN THE GUIDE RAIL.....	21
FIGURE 15: INSTALLING PANEL CONNECTORS.....	22
FIGURE 16; ORIENTATION OF THE MIDDLE PANEL IN RELATION TO THE FRONT FACE PANEL.....	22
FIGURE 17: POSITIONING THE MIDDLE PANEL PRIOR TO INSTALLATION .....	23
FIGURE 18: JOINING THE PANELS TOGETHER .....	23
FIGURE 19: FILLING IN BETWEEN THE DOOR SEGMENT AND THE GATE PANEL.....	24
FIGURE 20: PREPARING THE END PANEL FOR INSTALLATION .....	24
FIGURE 21: WALL-MOUNTED GATE STOPPER.....	25
FIGURE 22: INSTALLING THE WALL-MOUNTED GATE STOPPER.....	26
FIGURE 23: CHECKING THE WALL-MOUNTED GATE STOPPER FOR PROPER INSTALLATION.....	27
FIGURE 24: INSTALLING THE GUIDE ROLLER .....	28
FIGURE 25: GATE LEAF POSITION PRIOR TO THE ROPE SYSTEM INSTALLATION .....	29
FIGURE 26: INSTALLING THE GATE'S ROPE SYSTEM .....	30
FIGURE 27: ROPE SYSTEM DIAGRAM FOR VARIOUS MULTI-PULLEY ARRANGEMENTS .....	31
FIGURE 28: INSTALLING THE ELECTROMAGNETIC KEEPER .....	32
FIGURE 29: INSTALLING THE ELECTROMAGNETIC KEEPER - LATERAL MOUNTING POSITION VARIANT.....	33
FIGURE 30: VIEW OF THE GATE'S ELECTRICAL EQUIPMENT INSTALLATION PLATE .....	33
FIGURE 31: INSTALLING THE POCKET - WALL PROTECTIVE COVER WITH FIRE-RESISTANT FILLING .....	35
FIGURE 32: INSTALLING THE BALLAST COVER (BALLAST AT THE GATE FRONT FACE SIDE) .....	36
FIGURE 33: INSTALLING THE BALLAST COVER (BALLAST AT THE GATE STOPPER SIDE).....	37
FIGURE 34: INSTALLING THE GATE LEAF'S FRONT FACE COVER AND ITS THRESHOLD COVERS .....	38
FIGURE 35: INSTALLING THE LINTEL COVER .....	39
FIGURE 36: INSTALLING GUIDE RAIL COVERS .....	41
FIGURE 37: LAYOUT VARIANTS OF THE GATE'S ELECTRIC DRIVE .....	42

# 1. Introduction

This Assembly Manual (further referred to as the Manual) refers to the products made by Małkowski - Martech S.A. (further referred to as the Manufacturer), and it is only designed for installation and maintenance teams authorised by the Manufacturer. This Manual contains some guidelines on proper sequence of activities in order to provide for appropriate and safe installation.

## 2. Information concerning revisions to the manual

Compared to the previous version of Assembly Manual no. \_\_\_\_\_, the following revisions, as listed in the Table below, have been made to this Manual:

No.	Revision date	Revision location in the Manual	Revision description

### 3. Related documents

- PN-EN 12635+A1:2010 Industrial, commercial and garage doors and gates – Installation and use;
- PN-EN 12433:1999 Industrial, commercial and garage doors and gates – Installation and use – Terminology – Part 1: Types of gates;
- PN-EN 12433-2:1999 Industrial, commercial and garage doors and gates – Installation and use – Terminology – Part 2: Parts of gates;
- PN-EN 12453:2002 Industrial, commercial and garage doors and gates – Installation and use – Safe use of power operated gates – Requirements;
- PN-EN 13411-5:2005 – Terminations for steel wire ropes;
- Technical Approval AT-15-5023/2012;
- Certificate of Conformance ITB-1428/W;
- Operation and Maintenance Manual;
- Assembly Conditions Assessment Chart (if applicable);
- Measurements Form;
- Assembly Chart;

## 4. Preparation to the assembly work

### 4.1. Building conditions

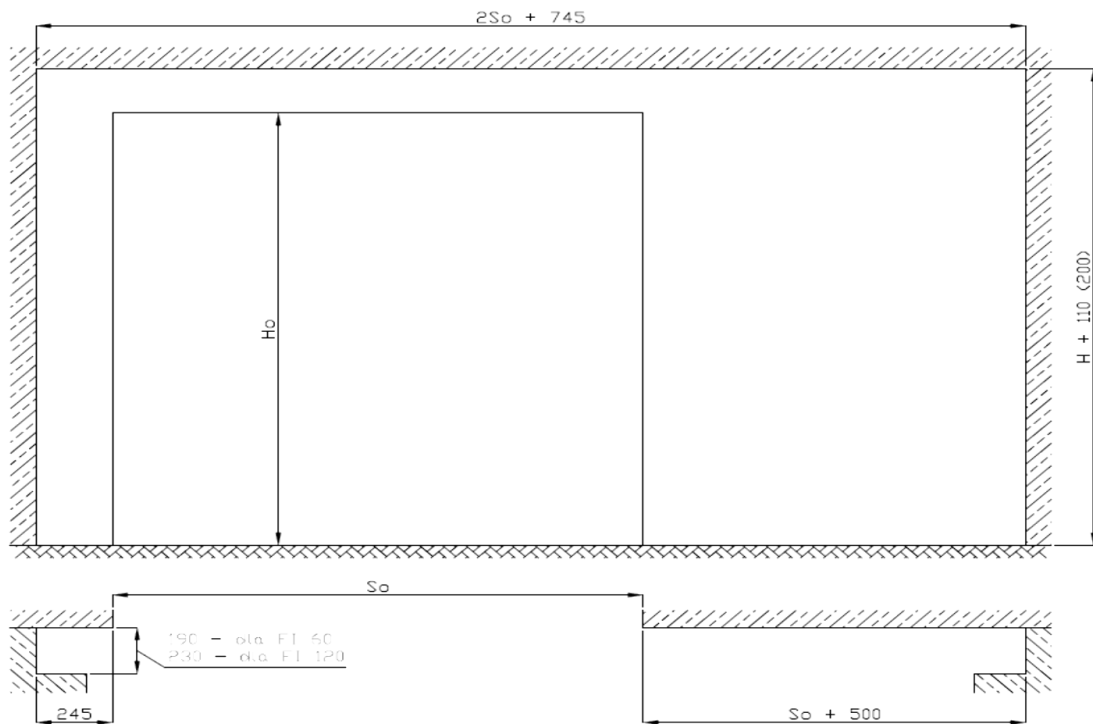

Figure 1: Operation area of the gate

### 4.2. Assembly documents

- Assembly Report;
- Measurements Form;
- Assembly Conditions Assessment Chart (if applicable);
- Assembly Chart;
- Stock Issue Confirmation;

### 4.3. Assembly tools

- hammer drill;
- battery-operated drill-driver;
- riveter;
- level;
- angle grinder;

## 4.4. Parts

No.	Shipped parts	Assembly parts	Shipped connectors	Assembly connectors
1	Front face panel; Middle panel; Door segment; Door leaf; End panel; Swelling gasket; Threshold cover; Front face cover; Front face lower fitting; Upper profile connector; Hat profile connector; Swelling gasket; Right/ left bent magnet keeper support (for lateral installation)		Mounting adhesive; Screw M8x20; Plain washer 8.4; Nut M8; Tap screw ST 4.2x19; Screw M12x100; Washer 12,5; Screw M8x16 with countersunk head; Upper profile connector; Hat profile connector;	Steel rivets 4.0x10 Tap screw ST 4.2x13; Tap screw ST 4.2x19;
2	Front module (end roller receiver) Wall-mounted support		Nut M10; Screw M8x30;	Steel anchor M10x100 (at the Fitter's side) Door frame anchor M10 x 72(52) (at the fitter's side)
3	Guide rail 4000 mm; Resulting guide rail; Wall-mounted supports;	Guide rail 4000; Resulting guide rail;	Lock screw M10x50; Nut M10; Washer Ø10; Screw M8x30;	Steel anchor M10 x 100 (at the fitter's side) Steel rivets 4.0x10
	Guide rail connector; Electromagnetic keeper assembly;		Screw M8x30; Washer 8.4; Nut M8 Tap screws ST 4.2x13	
4	Wall-mounted gate stopper; Swelling gasket;			Steel door frame anchor M8 x 72(52) (at the fitter's side)
5	Guide roller			Steel door frame anchor M8 x 72(52) (at the fitter's side)
6			Rope clamp (size dependent on rope diameter); Rope thimble (size dependent on rope diameter);	
7	Ballast cover; Ballast cover clip;		Steel rivets 4.5x12(16)	Steel door frame anchor M8x72 (52)



	Lintel cover; Lintel cover clip; GKF boards 12,5x125xSo; Side track cover; Front face track cover; Track cover angle bar; Front face track cover connector;		(at the fitter's side); Steel rivets 4.5x12(16);
--	---	--	--

## 5. Fire-resistant sliding gate assembly stages

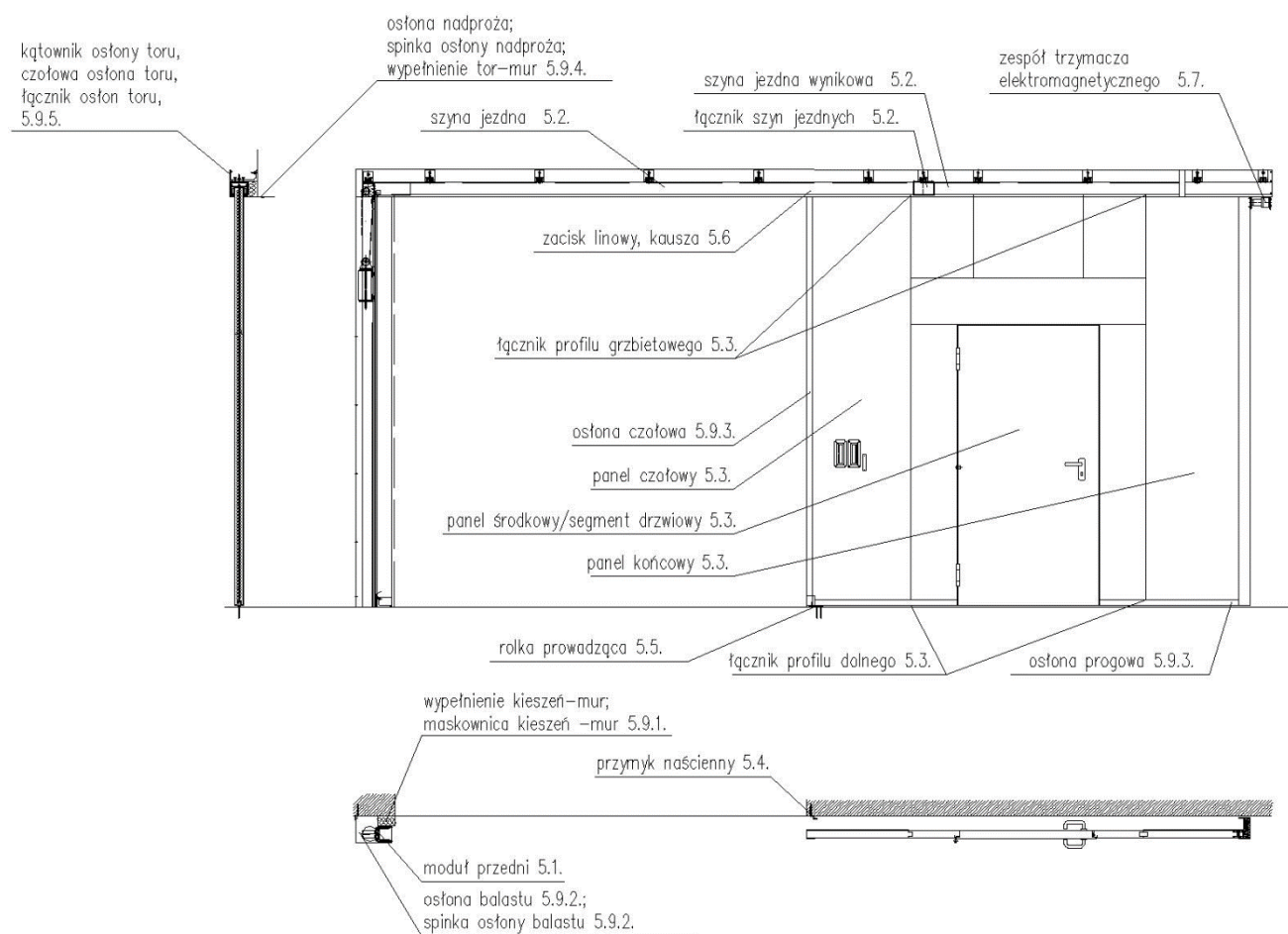

Figure 2: Layout of gate assembly elements

## 5.1. Installing the front module

**Note:** If the ballast weight makes it impossible to install the front module successfully, remove the ballast by loosening the M8 nut (Fig. 3).

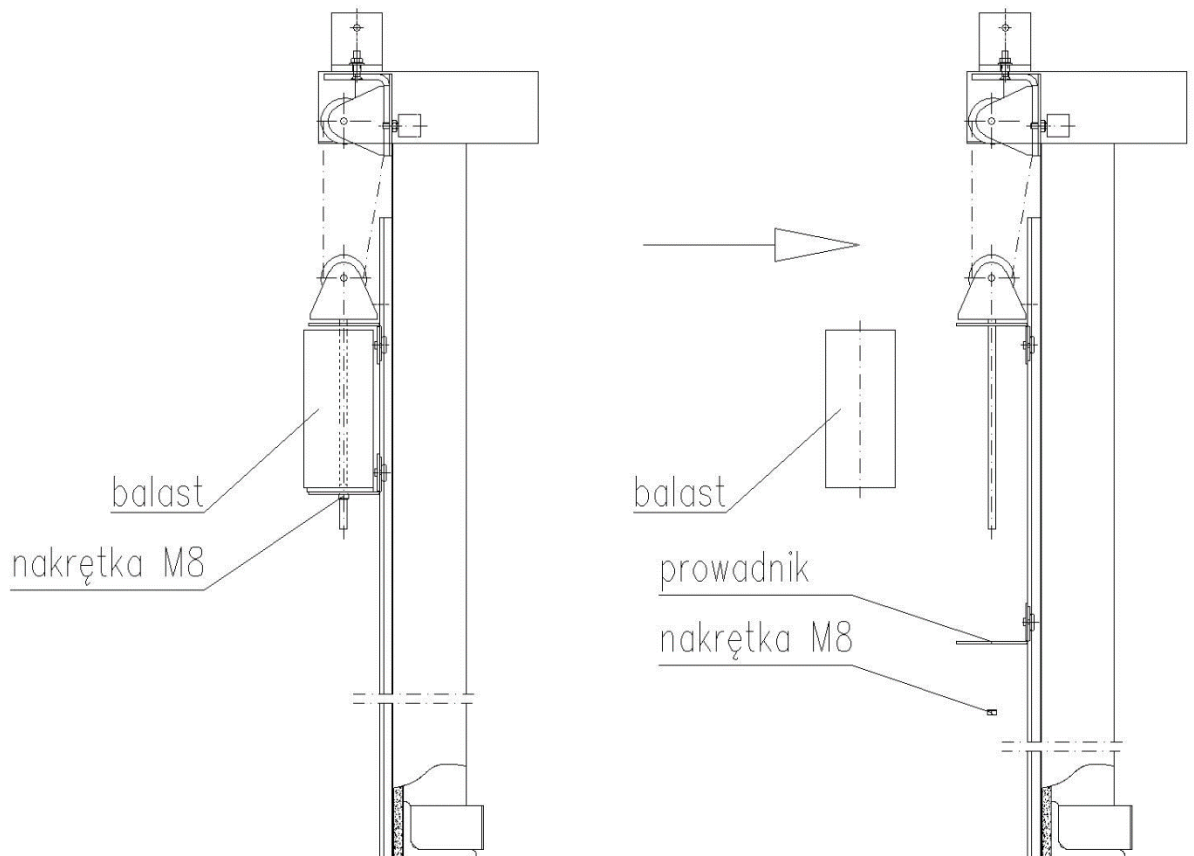

Figure 3: Front module - ballast removal

- Set front module in relation to the edge of the hole (Fig. 4);
- Check if the module's position is vertical; adjust if required;

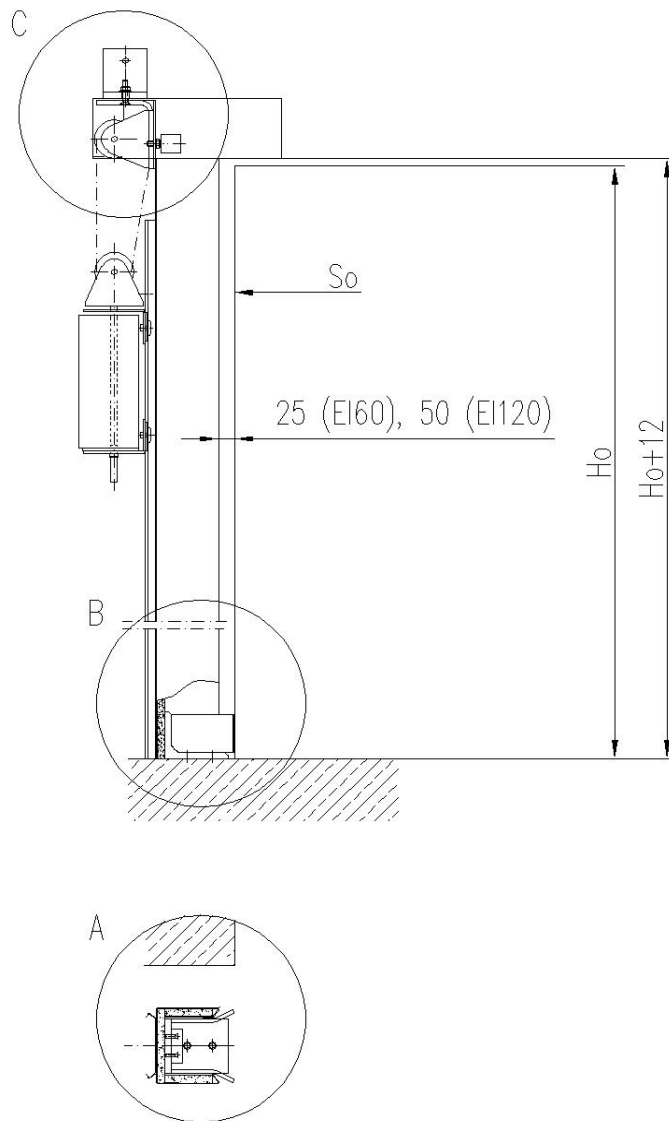

Figure 4: Front module - position in relation to the edge of the hole

- Mount the front module on the floor, using two steel door frame anchors M8x72(52) (Fig. 5 – detail B and C);
- Mount the front module on the wall through the wall-mounted support, using steel anchor M10, (Fig. 5 – detail A, for the steel construction Fig. 6).

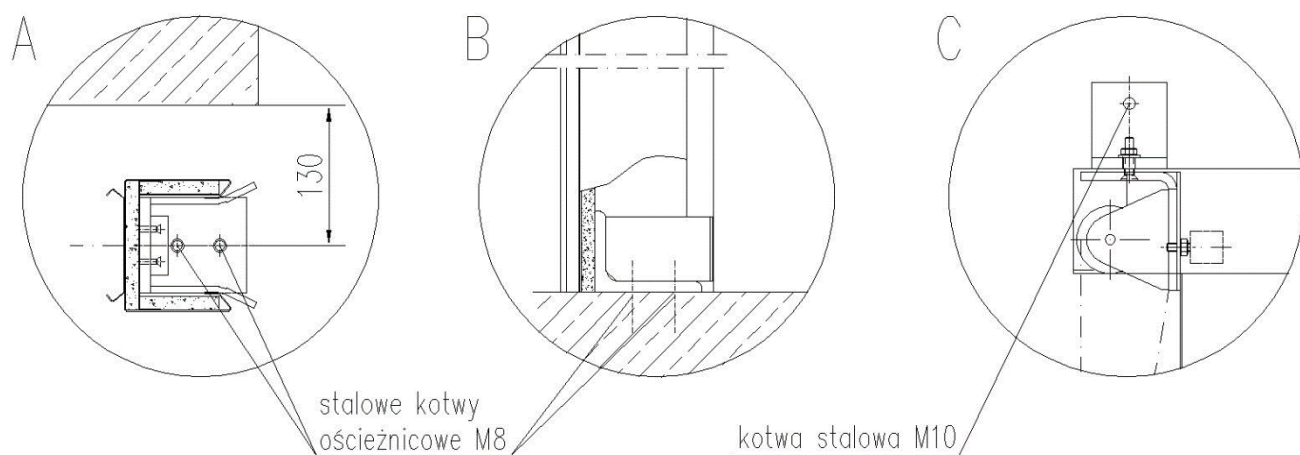

Figure 5: Front module - assembly

- Install the front module to the steel construction using screws M10 with nuts and washers (Fig. 6);

**Note:** the steel construction must be secured to the required fire resistance class (minimum fire-resistance class of the gate).

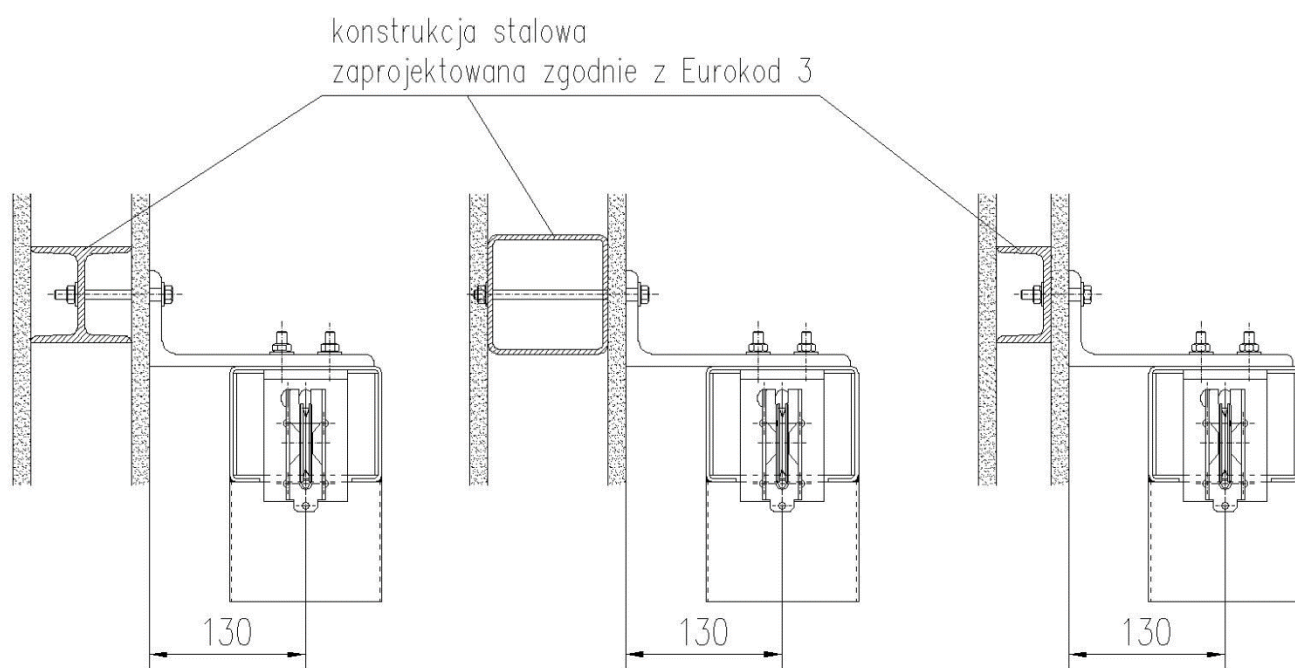

Figure 6: Front module - fixing it to the steel construction

- The gate should be mounted in other types of walls, e.g. masonry walls built in SILKA or YTONG systems, in the pass-through arrangement, using M10 threaded pins with washers or special anchors designed for use with a given wall type;

**Note:** *In case the gate is installed in “lightweight” walls, their load-bearing capacities should be taken into account.*

## 5.2. Installing the guide rail

- Fasten wall-mounted supports to the guide rail, using lock screws M10x50 with nuts M10 and two hexagon bolts M8x30 spaced as in Fig. 7;

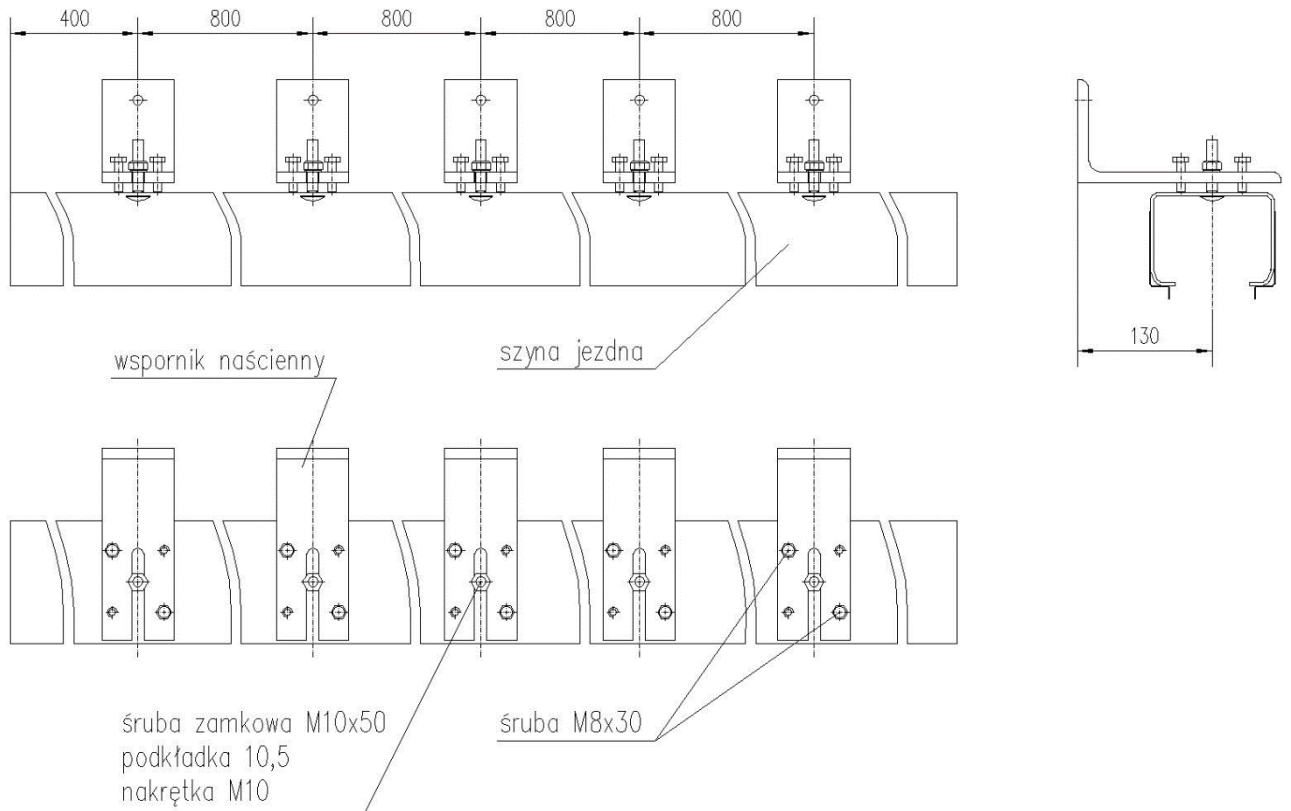

Figure 7: Completing the guide rail length

- Slide the complete guide rail into the installed front module to the depth of approx. 20 cm, till you feel sharp resistance (Fig. 8);
- Place the guide rail upright in the parallel plane to the surface of the lintel;
- In the lintel wall, make some fixing holes with the diameter that corresponds to the one of the anchoring element used, in line with the axis of holes in guide rail supports;
- Through the supports, drive M10 steel anchors into the holes that you have just made;
- Screw on the wall-mounted supports, using M10 nuts;

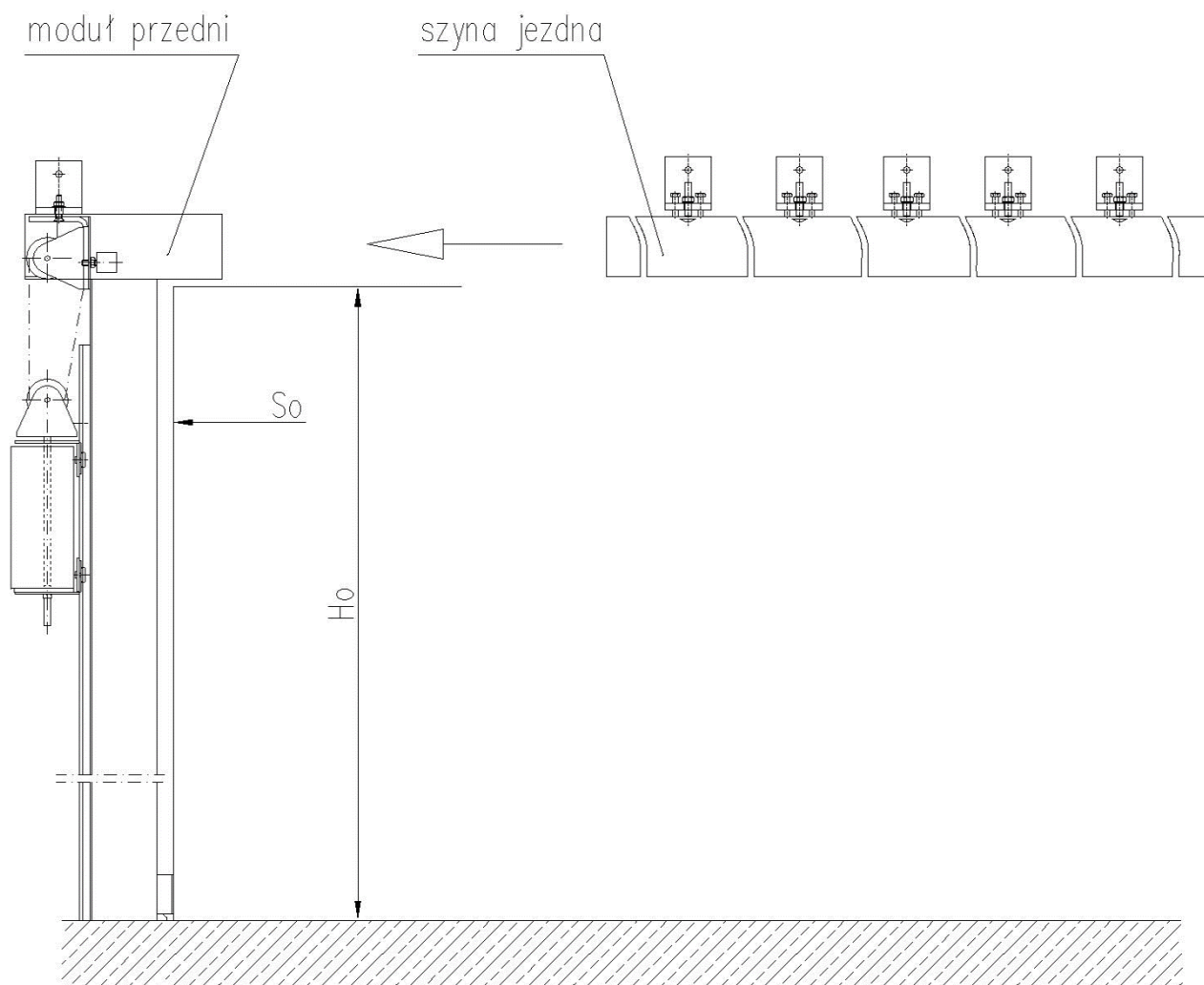

Figure 8: Installing the first guide rail length

- Check for correctness of guide rail levelling in the parallel and perpendicular plane to the wall;

**Note:** If required, level the guide rail using screws M8x30.



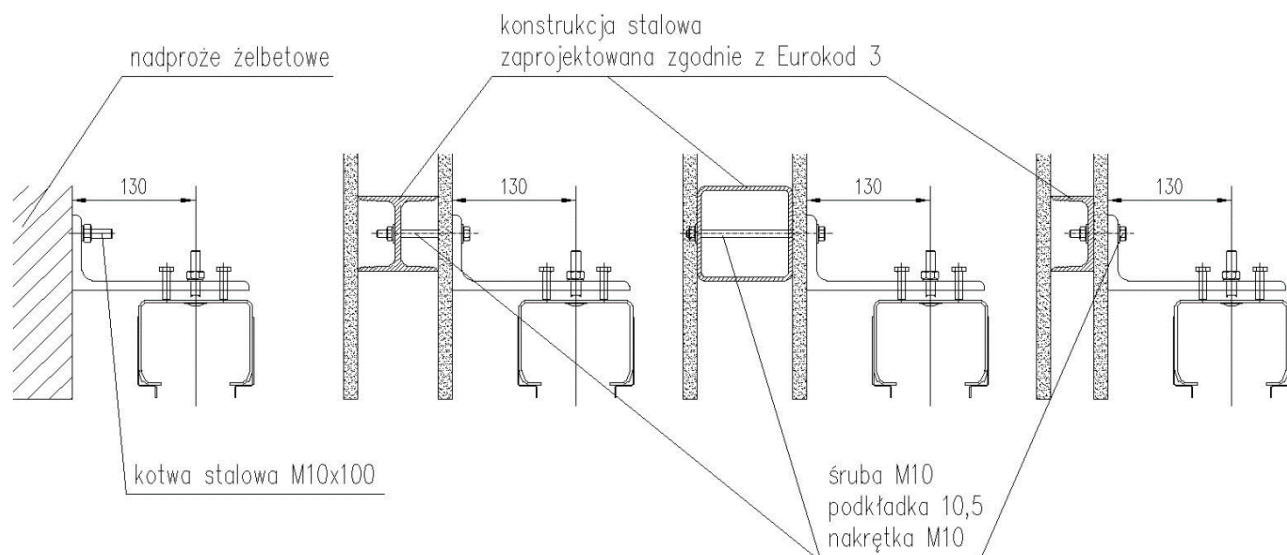

Figure 9: Installing the guide rail depending on lintel material

**Note:** The gate should be mounted in other types of walls, e.g. masonry walls built in SILKA or YTONG systems, in the pass-through arrangement, using threaded pins M10 with washers or special anchors designed for use in a given wall type. In case the gate is fixed to “lightweight” walls, their load-bearing capacities must be accounted for.

- Slide the guide rail connector onto the rail to the depth of 7.5 cm;

**Note:** The guide rail connector is a clamping ring whose cross-section is similar to that of the guide rail.

- Install the wall-mounted support on the M10 thread of the guide rail joint.
- Fasten the wall-mounted support to the wall, using the M10 steel anchor;
- Slide the next guide rail length into the guide rail joint;

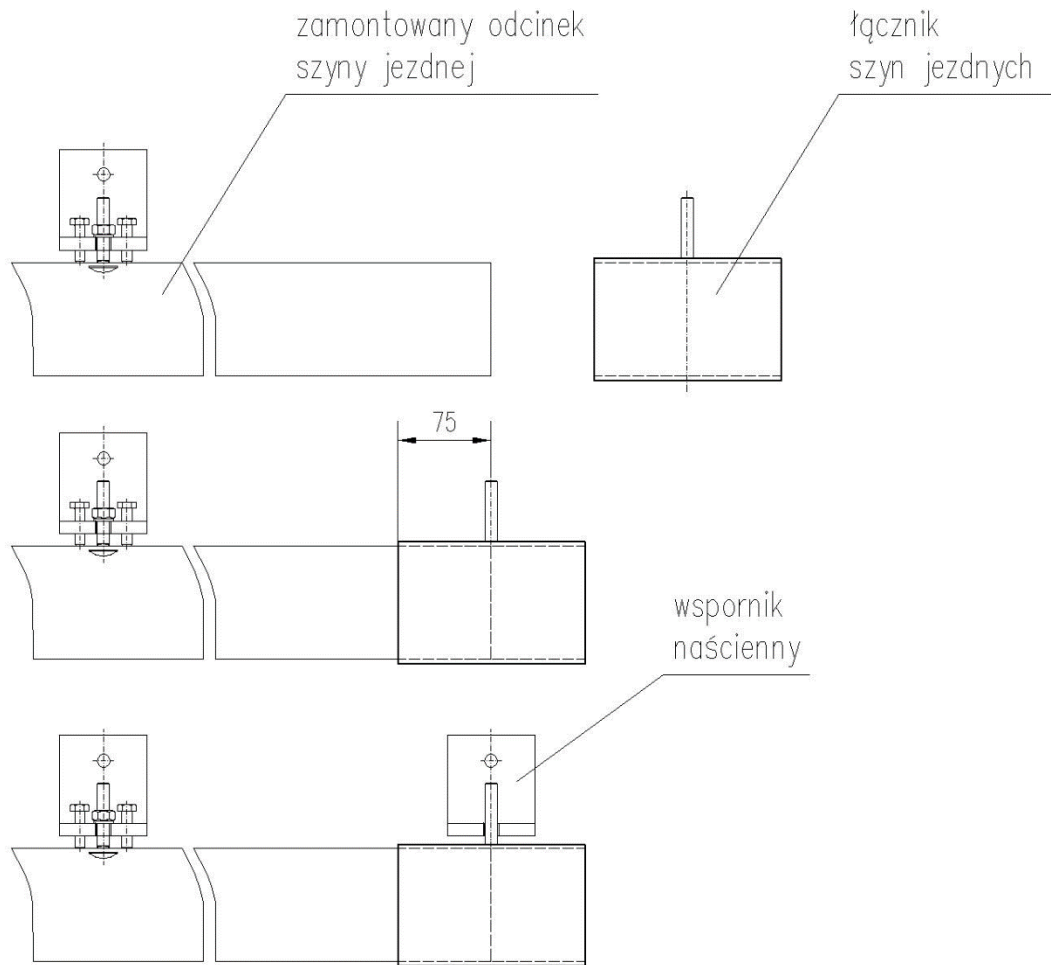

Figure 10: Installing the guide rail connector

**Note:** The protruding end of the guide rail connector makes room for the next guide rail length being installed

- Slide the next guide rail length into the guide rail joint;
- Fasten the wall-mounted supports of the length being installed to the lintel in the same way as the previous length;
- Using screws M8x30, press the guide rails being joined against the lower foot of the connector, and fasten the connector to the adjacent guide rail lengths using the M10 nut;

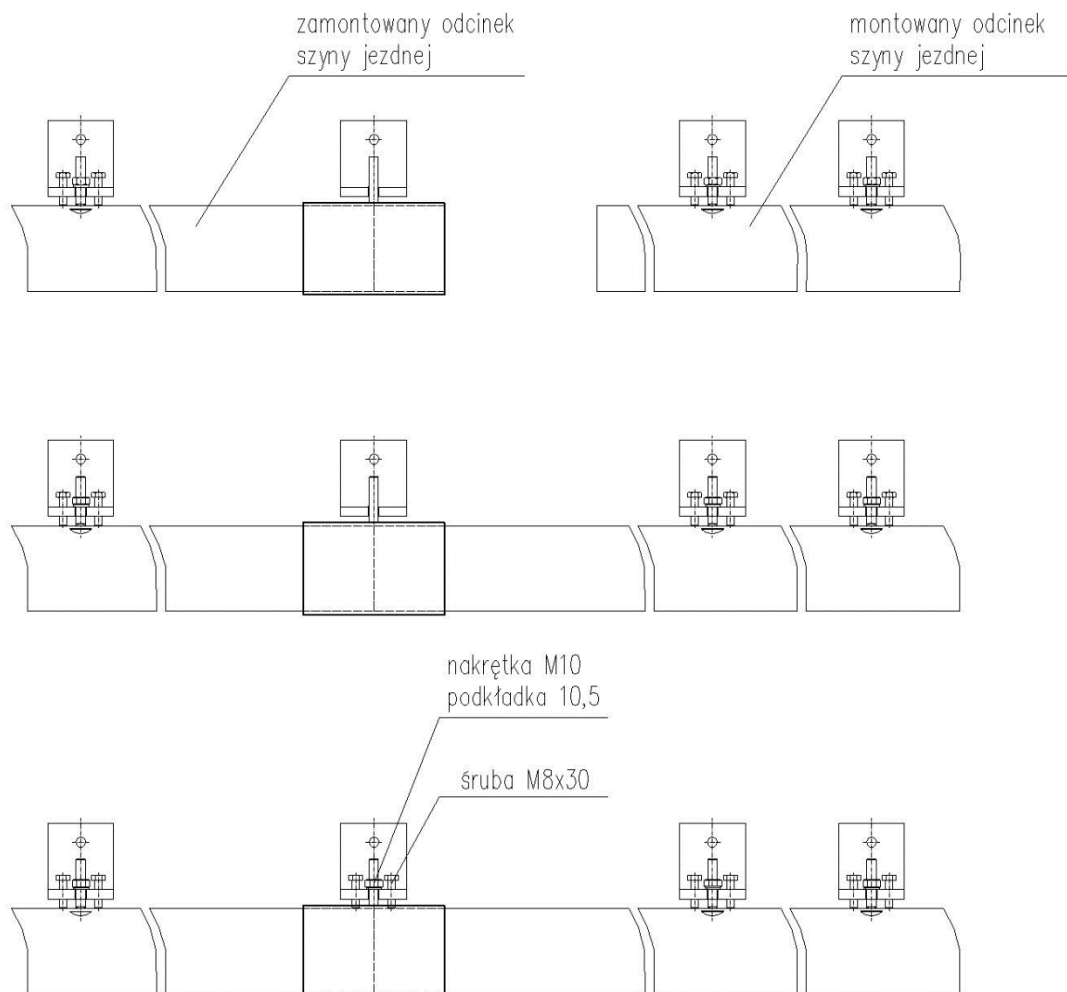

Figure 11: Installing the next guide rail lengths

- The remaining guide rail lengths (the quantity of which depends on the width of the building hole) should be mounted in the same way, ending with the resulting length (less than 4000 mm long);

### 5.3. Installing gate leaf panels

- Move the panels into the gate installation site;

**Note:** Panels should be moved in their upright position. Moving panels in their horizontal position may result in their permanent damage.

- Partially remove the protective film from the panels;

**Note:** What is meant here is panel joining areas; places that will be inaccessible after the panels have been glued together.

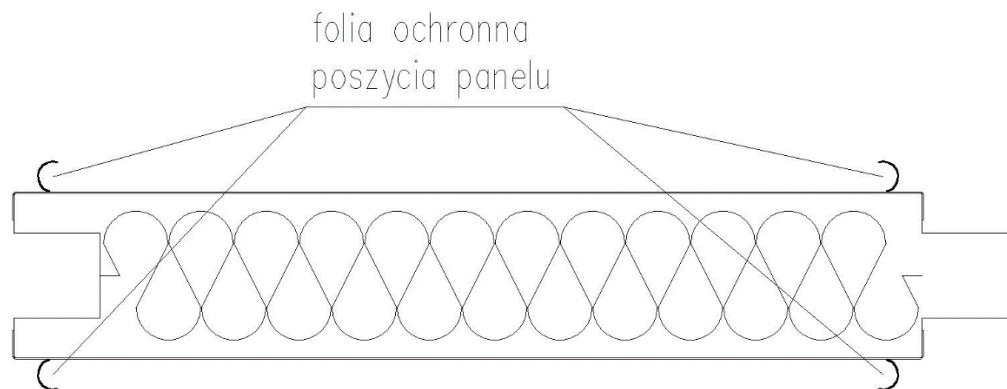

Figure 12: Removing the protective film from the panel surface

**Note:** Gate leaf panels are designed in such a way that it is possible to install them in their upright position. Be careful while lifting gate leaf panels to avoid them being damaged (risk of panel filling rupture). In order to put up the panels that are more than 4 m high, it is recommended to use additional framework stiffening constructions, scissor lift tables, scaffolding, etc.

**Note:** The panel assembly sequence depends on specific building conditions at the building site. The Manual illustrates the panel assembly sequence, starting from the front face panel.

- Carefully place the front face panel in the upright position;
- Orientate the panel in relation to the front module;

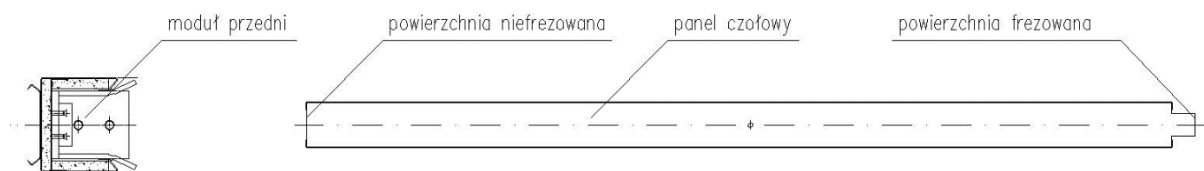

Figure 13: Orientation of the front face panel in relation to the front module

- Place the front face panel in the guide rail;

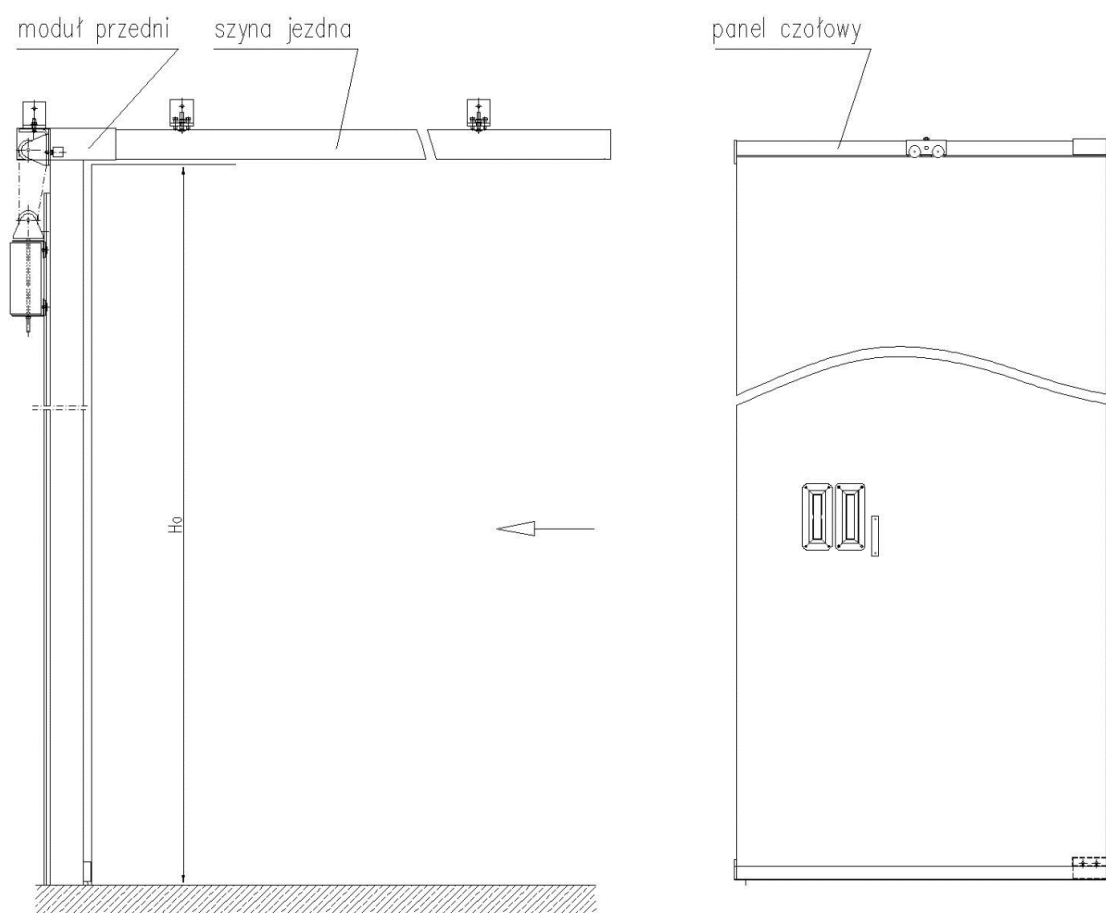

Figure 14: Placing the front face panel in the guide rail

- Slide upper and lower profile connectors on middle panel fittings;
- Screw the connectors together with middle panel fittings, using self-tapping screws;

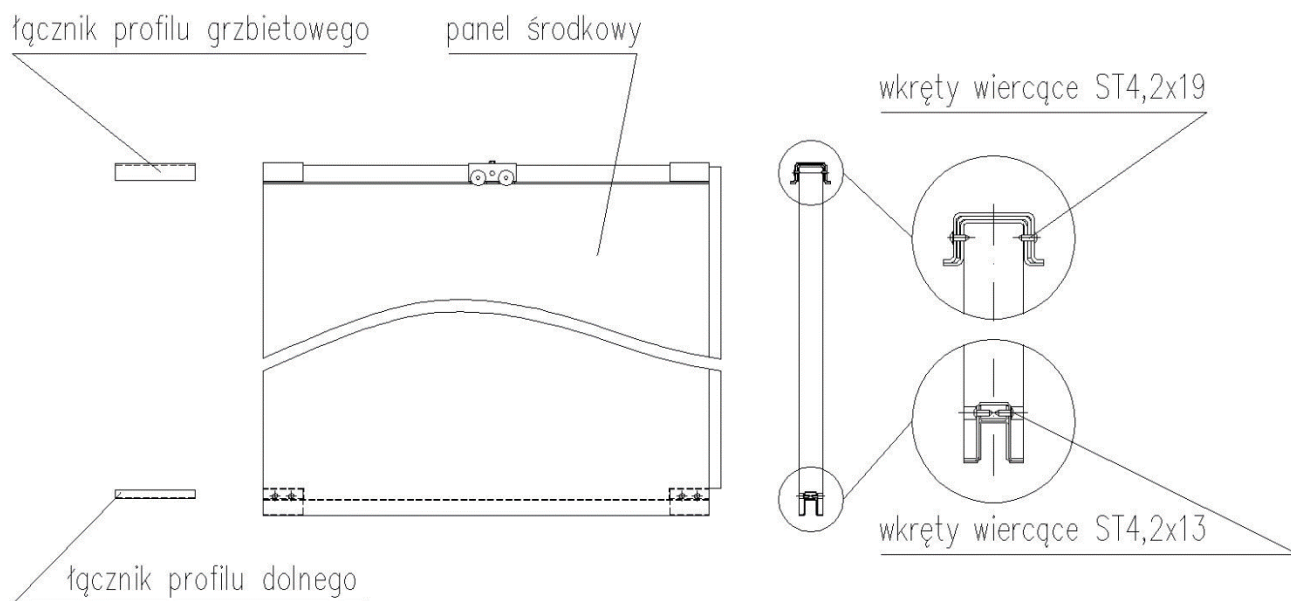

Figure 15: Installing panel connectors

- Carefully put the middle panel up in the upright position;
- Orientate the panel in relation to the front face panel;

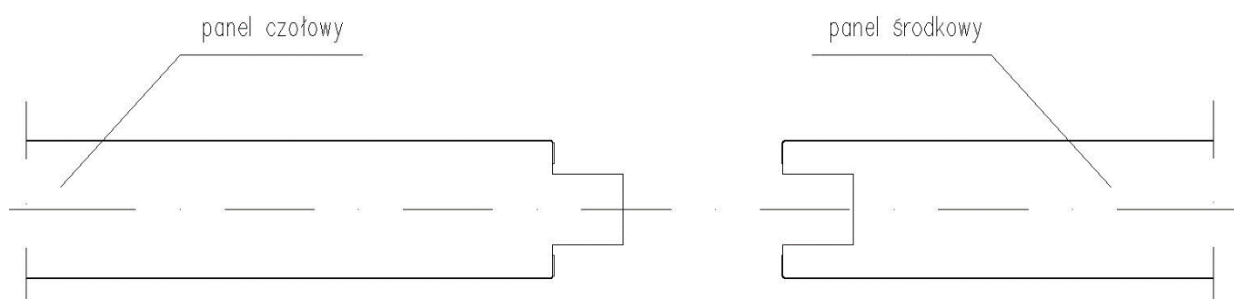

Figure 16: Orientation of the middle panel in relation to the front face panel

- Place the middle panel on the plate, near the guide rail;

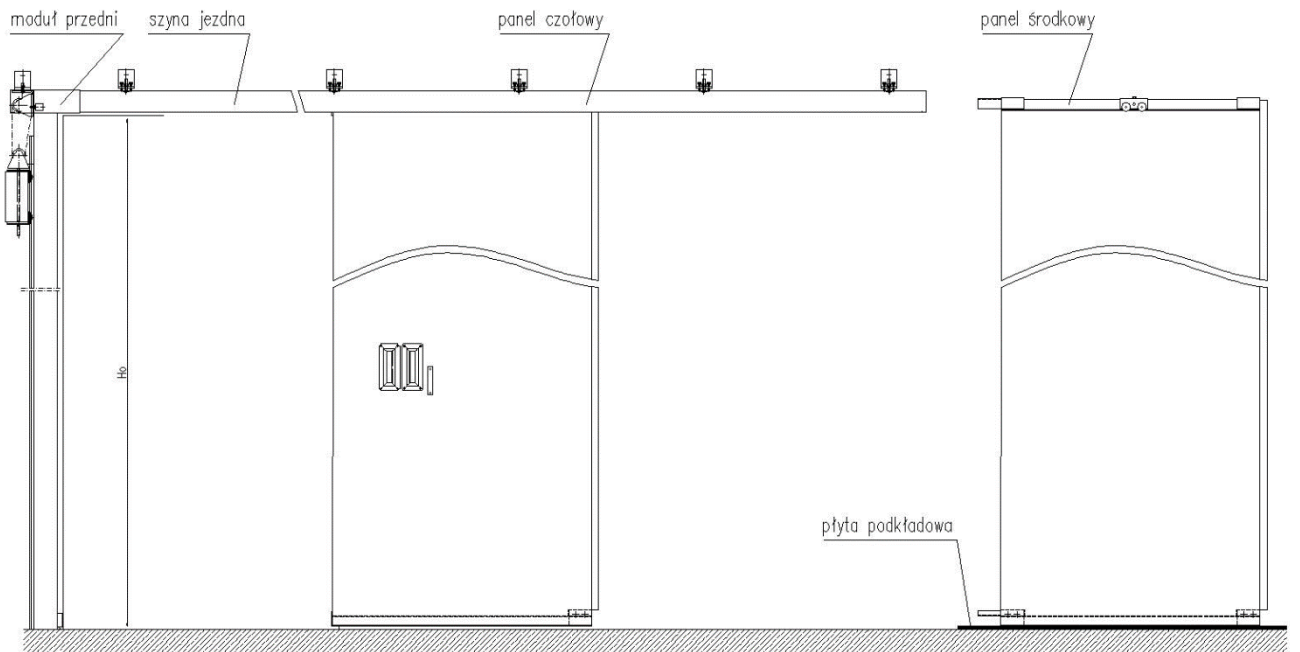

Figure 17: Positioning the middle panel prior to installation

- Withdraw the front face panel in the direction of the middle panel;
- Assemble the panels together in such a way that connectors placed in the middle panel can slide into front face panel fittings;
- Be careful to avoid gaps along adjacent surfaces of the panels;
- Secure the panels' mutual position by strapping them with transport straps;

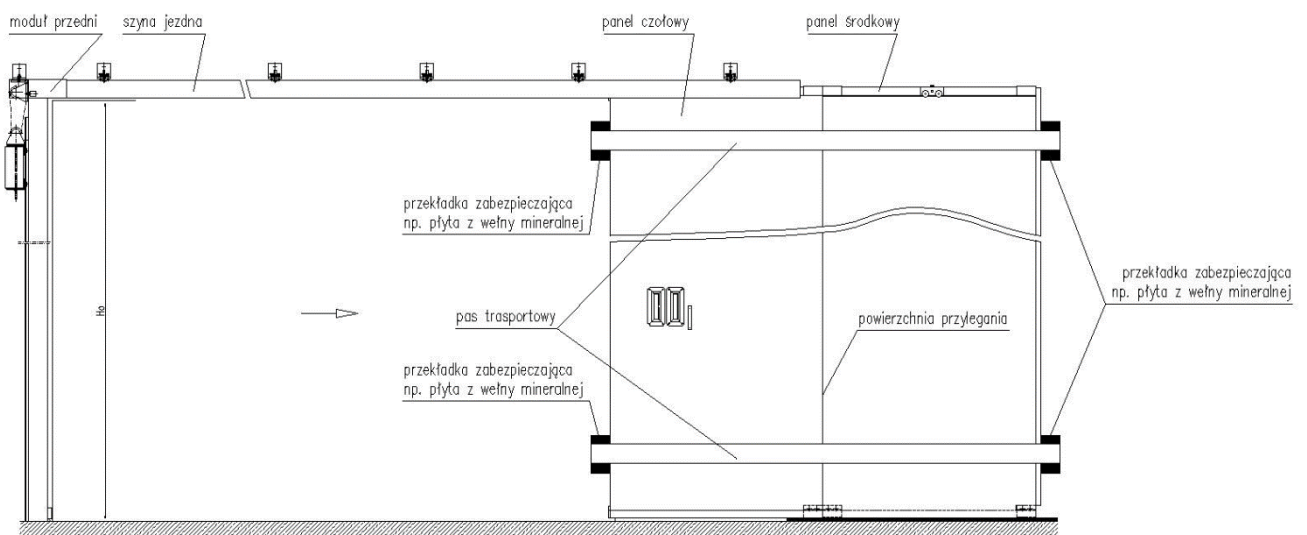

Figure 18: Joining the panels together

- Join the panels together, using self tapping-screws ST 4.2x13(19) (Fig.15);
- Slide the joined panels into the guide rail;

**Note:** If the gate leaf consists of a higher amount of middle panels, they should be mounted in the same way as the first middle panel.

**Note:** The door segment should be installed in the same way as the gate leaf's middle panel. While installing it, pay attention to the door segment's orientation towards the wall (door opening direction). Door segment sides end with keys. As the side of the next panel (adjacent with the door segment) also ends with a key, the arising space should be filled with mineral wool board with cross-section dimensions of 60 x 30 mm.

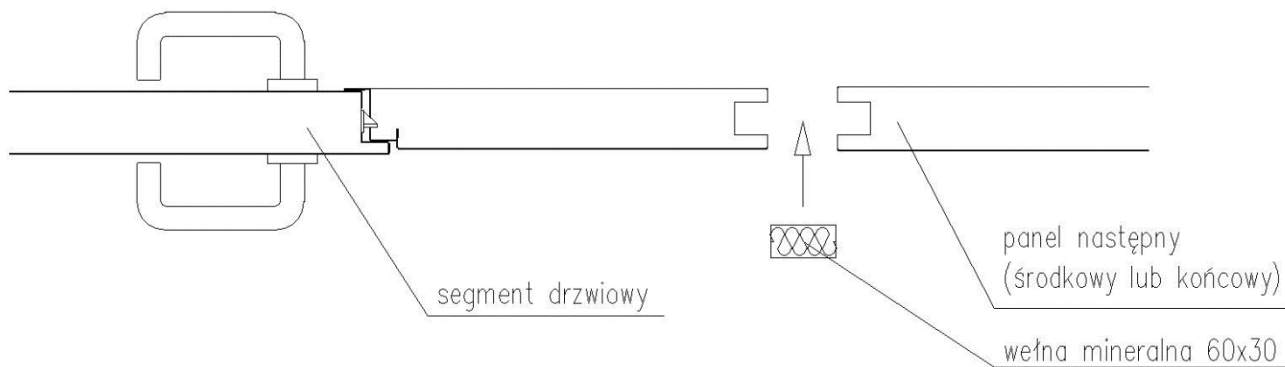

Figure 19: Filling in between the door segment and the gate panel

- Attach the swelling gasket at the inner surface of the leaf-mounted gate stopper at its entire height;

**Note:** The leaf-mounted gate stopper is an integral part of the gate leaf's end panel. The end panel should be installed in the same way as middle panels.



Figure 20: Preparing the end panel for installation



## 5.4. Installing the wall-mounted gate stopper

**Note:** The wall-mounted gate stopper is:

- profile “Z” for EI60 gates,
- profile “Z”, firestop plate and cover for EI120 gates.
- Attach the swelling gasket at the entire height of the gate stopper.

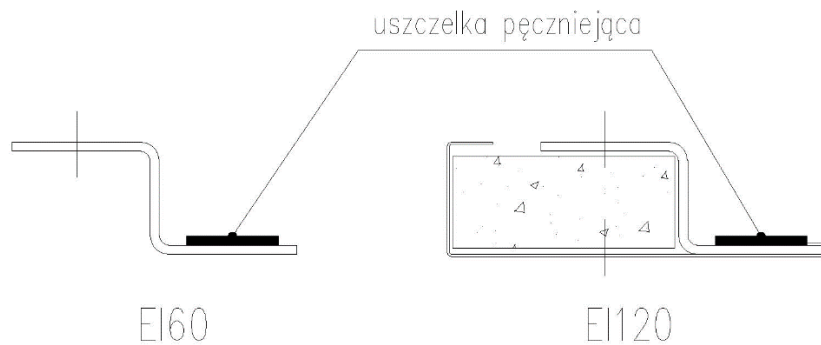

Figure 21: Wall-mounted gate stopper

Put the gate leaf in its open position (outside the hole) approx. 300 mm away from the edge of the hole;

- The wall-mounted gate stopper should be fixed to the wall using M8 door frame anchors (screws with nuts and washers to fix it to the steel construction) spaced each ~600 mm;

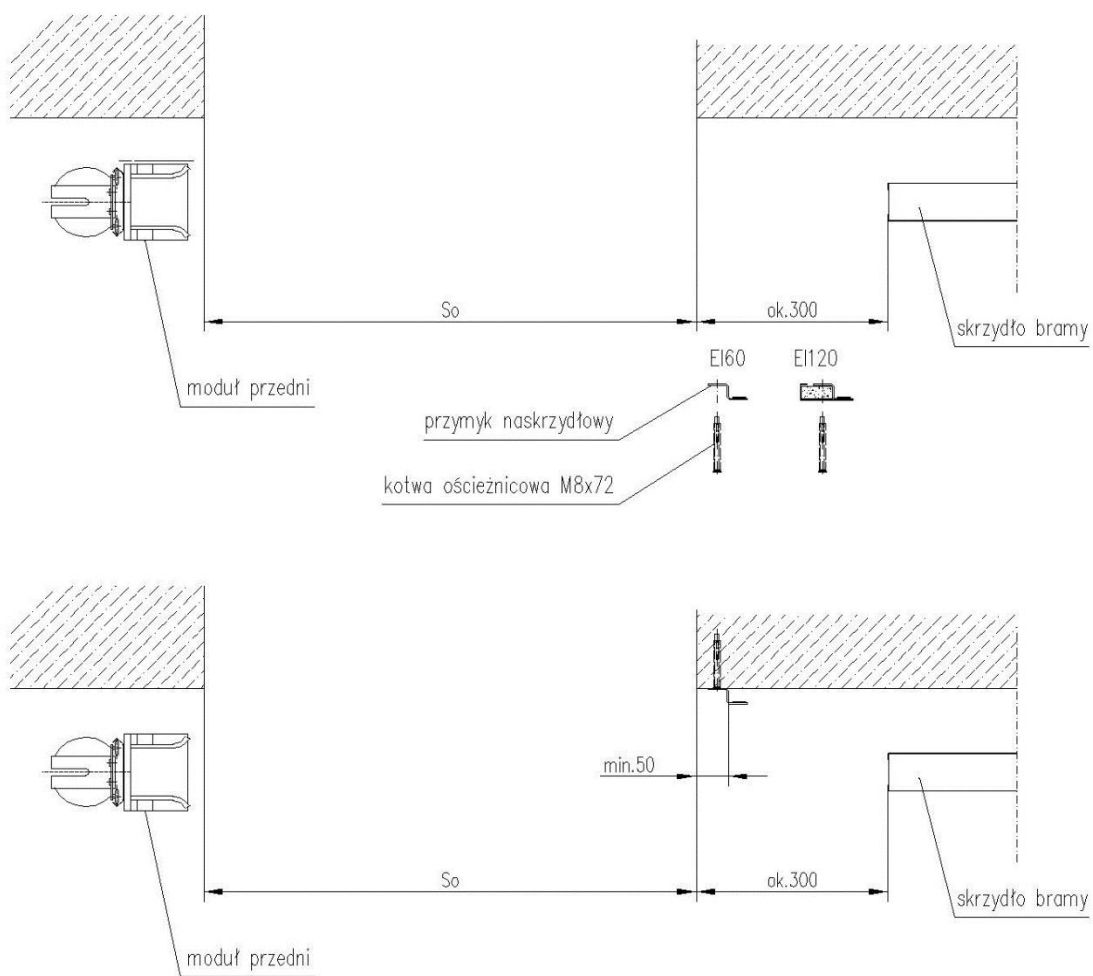

Figure 22: Installing the wall-mounted gate stopper

- Check the labyrinth seal of the wall-mounted gate stopper and leaf-mounted stopper for correct installation;

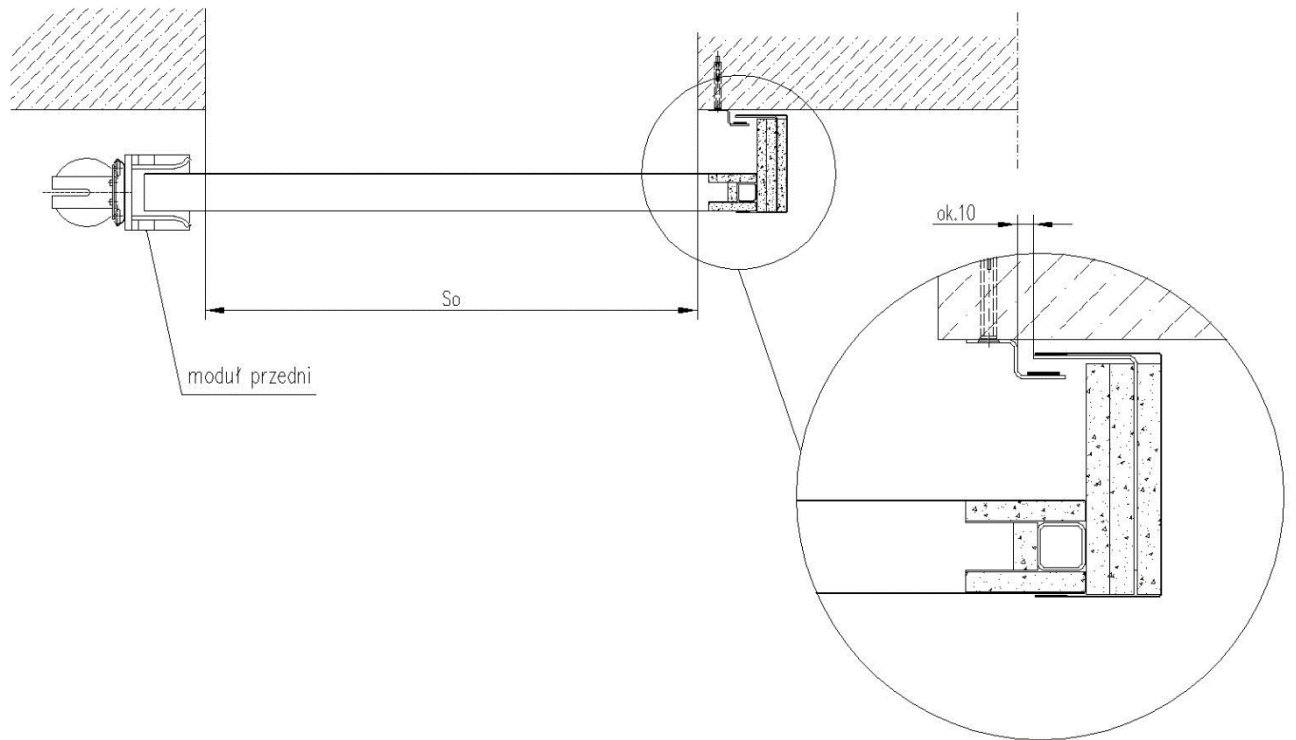

Figure 23: Checking the wall-mounted gate stopper for proper installation

## 5.5. Installing the guide roller

- Put the gate leaf in its open position (outside the hole) approx. 300 mm away from the edge of the hole;
- Fasten the guide roller to the floor near the edge of the hole, within the axis of the gate leaf, using steel door frame anchors M8;

**Note:** The guide roller should be set in such a way as to keep the gate leaf upright.

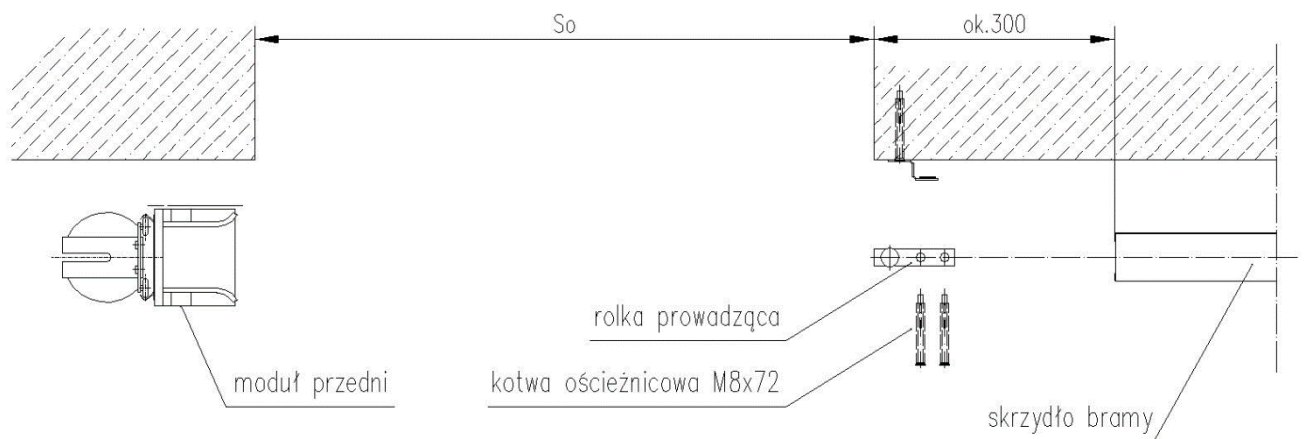

Figure 24: Installing the guide roller

## 5.6. Installing the rope system and the ballast

**Note:** The ballast is secured by tap screws for transport, so these tap screws must be loosened prior to adjustment.

- Put the gate leaf in its open position;
- Fasten the steel wire rope to the gate leaf's front face using the hook eye;

**Note:** The rope is fixed to the ballast at the factory.

**Note:** The counterbalance should be situated in its extreme top position.

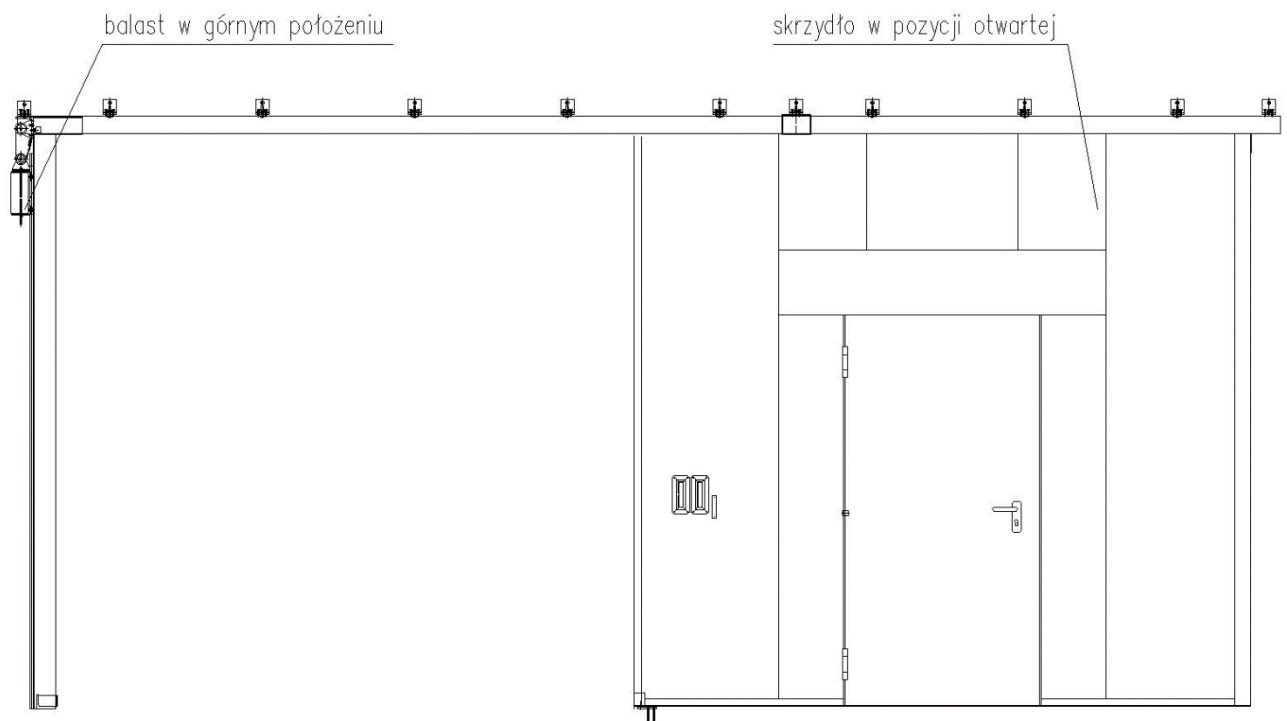

Figure 25: Gate leaf position prior to the rope system installation

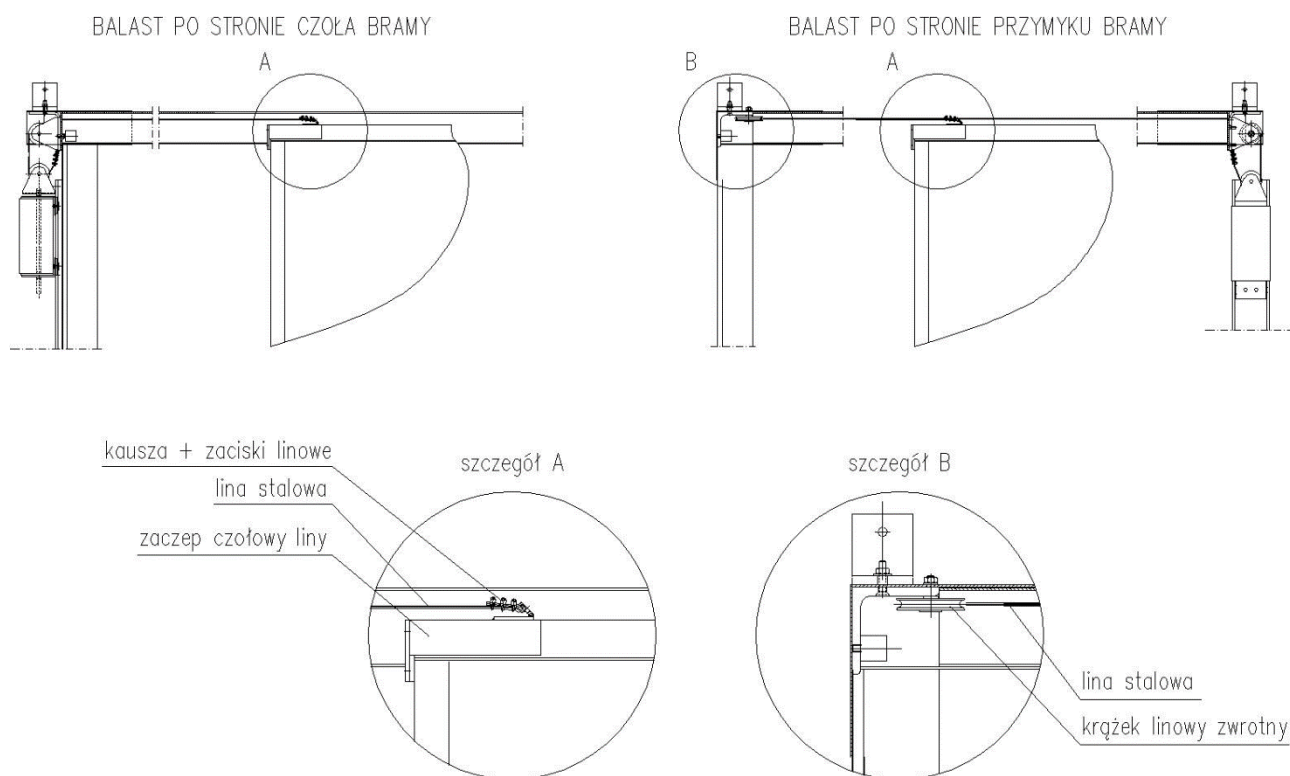

Figure 26: Installing the gate's rope system

**Note:** The steel wire rope must be fixed to the gate leaf in accordance with PN-EN 13411-5:2005.

**Note:** In case gate width is higher than its height, use ballast rings to provide for the gate's proper travelling range by using a multi-pulley arrangement.

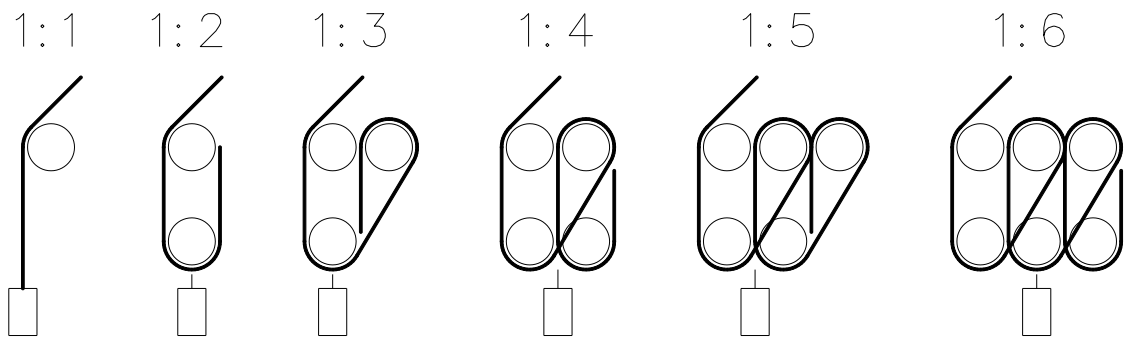

Figure 27: Rope system diagram for various multi-pulley arrangements

## 5.7. Installing the electromagnetic keeper

- Place the gate leaf in its open position in such a way that the gate front face is clear of the clearance of the hole;
- Determine the fixing place of the electromagnetic keeper support in such a way that the magnet keeper and the electromagnetic keeper are in touch;
- Make holes  $\varnothing 9$  in the guide rail for the electromagnetic keeper support;
- Fasten the support together with the electromagnetic keeper to the guide rail, using screws M8x30, washers 8.4 and nuts M8.

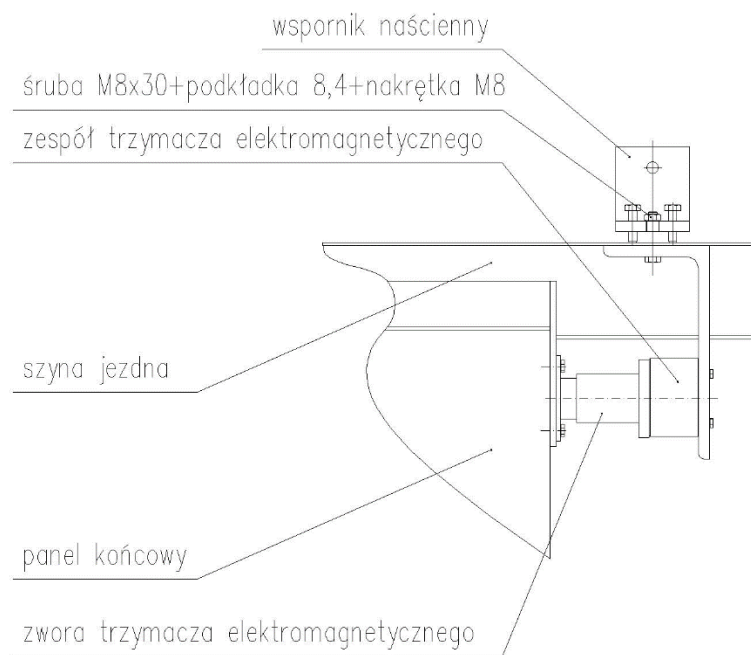

Figure 28: Installing the electromagnetic keeper

**Note:** In case building conditions at the building site make it impossible to install the electromagnetic keeper as above, the lateral mounting position should be used.



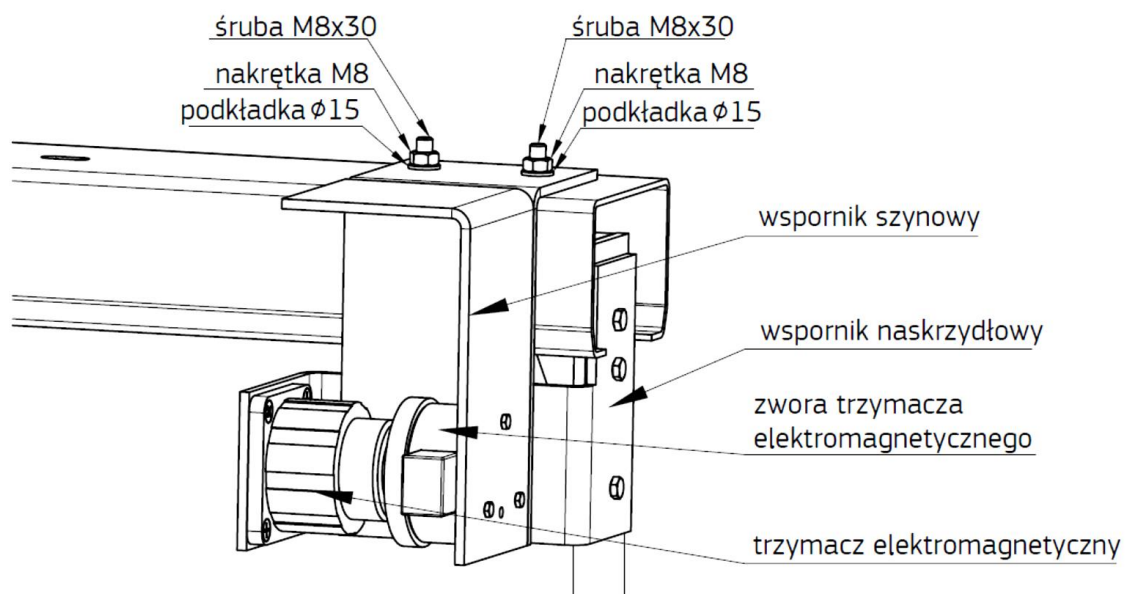

Figure 29: Installing the electromagnetic keeper - lateral mounting position variant

**Note:** The connection place of the electromagnetic keeper to the electrical equipment delivered by the Manufacturer is clearly indicated on the installation plate of such electrical equipment.

Electromagnetic  
keeper connection

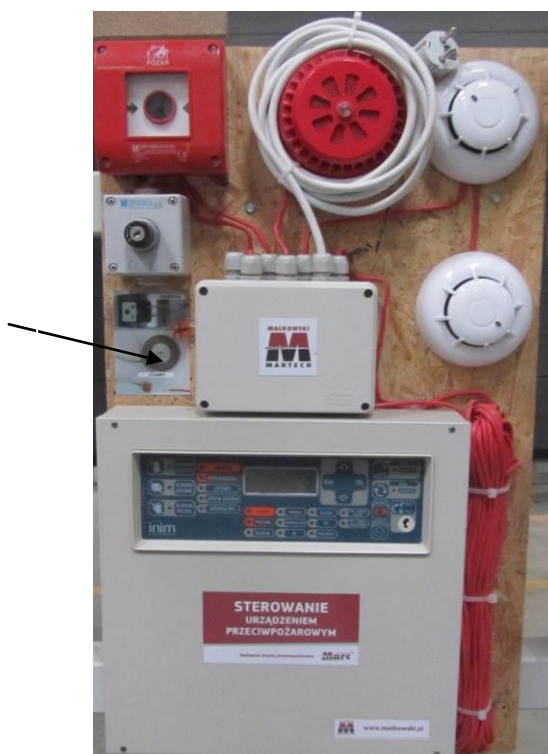

Figure 30: View of the gate's electrical equipment installation plate

## 5.8. Checking the gate leaf for closing properly

**Note:** Gate leaves must be able to close from each resting position;

- Measure the gate leaf's travelling speed

**Note:** Make the measurement at the initial length of the closing cycle. The gate leaf's travelling speed cannot be higher than 0.3 m/s. In case the gate leaf speed is too high, it may result in gate elements getting damaged.

**Note:** The capacity of the ballast delivered together with the gate is always higher than required. Be careful when the gate is operated for the first time. If required, adjust the counterbalance capacity by making a series of trial tests. Start your adjustments using the installed counterbalance.

## 5.9. Installing the covers

### 5.9.1. Installing the pocket - wall protective cover

- Fasten the cover to the wall, using steel door frame anchors M8 spaced approx. each 50 cm;
- The space in between the front module and the wall should be filled with mineral wool;

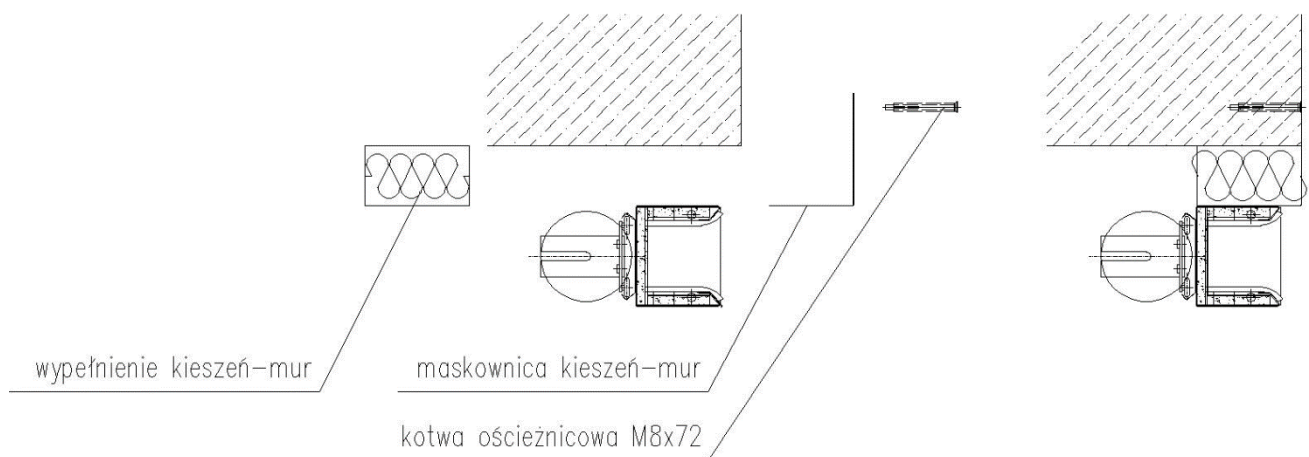

Figure 31: Installing the pocket - wall protective cover with fire-resistant filling

### 5.9.2. Installing the ballast cover (ballast at the gate leaf front face side)

- Fasten the clip to the wall using steel door frame, using anchors M8 spaced approx. each 50 cm;
- Place the ballast's protective cover behind the entry pocket of the front module;
- Slide the second edge into the clip;
- Join the cover with the clip, using steel rivets 4.0x10(13) spaced approx. each 50 cm;

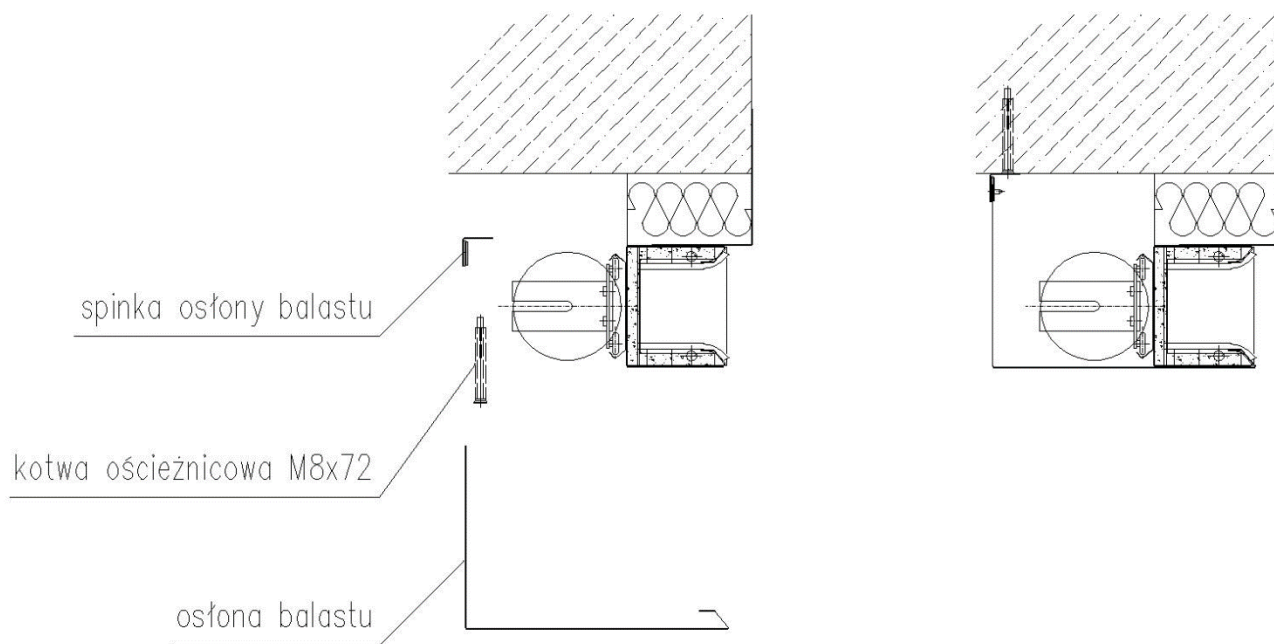

Figure 32: Installing the ballast cover (ballast at the gate front face side)

### 5.9.3. Installing the ballast cover (ballast at the gate stopper side)

Fasten two clips on the wall, using steel door frame anchors M8 spaced each ~50 cm;

- Mount the ballast cover, using steel rivets 4.0x10(13) mm, spaced each ~50 cm;

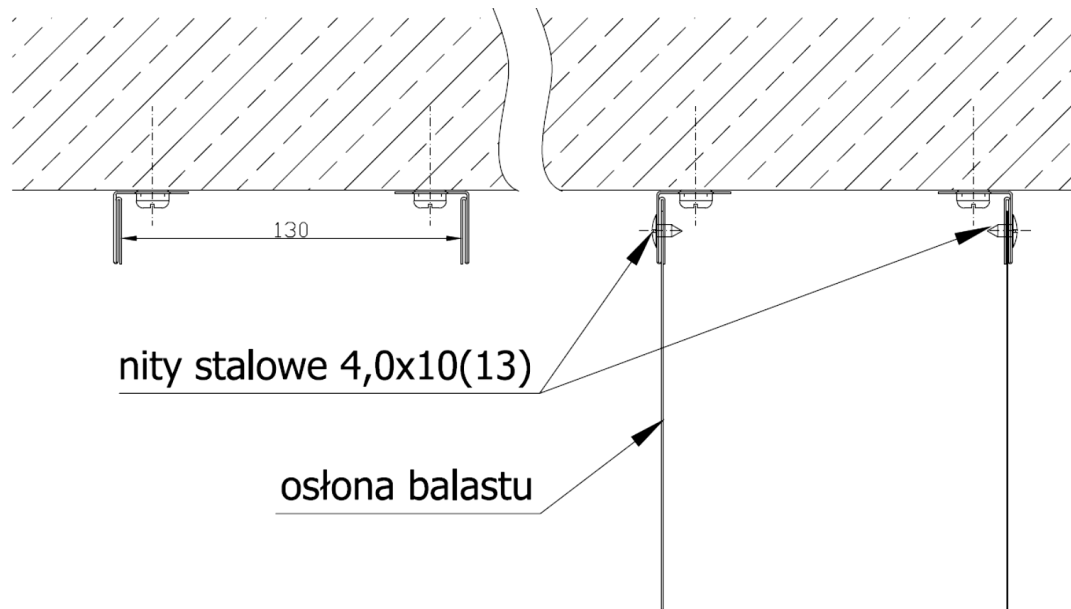

Figure 33: Installing the ballast cover (ballast at the gate stopper side)

## 5.9.4. Installing the gate leaf's front face masking cover and its threshold masking covers

**Note:** Gate leaf's finishing masking covers are:

- the front face cover with C-shaped cross-section;
- threshold covers with L-shaped cross-section;
- To fix the masking covers, use steel rivets 4.0x10 spaced approx. each 50 cm;

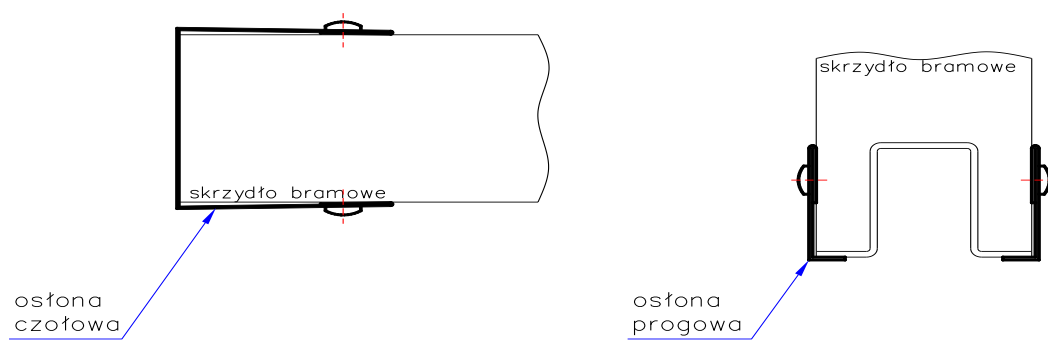

Figure 34: Installing the gate leaf's front face cover and its threshold covers

### 5.9.5. Installing the lintel cover

- Mount the lintel cover clip, using steel door frame anchors M8 spaced each ~50 cm;
- Fill the space between the guide rail and the lintel with mineral wool;
- Slide the lintel cover into the guide rail clip and the lintel clip;
- Mount the cover together with the firestop plate;

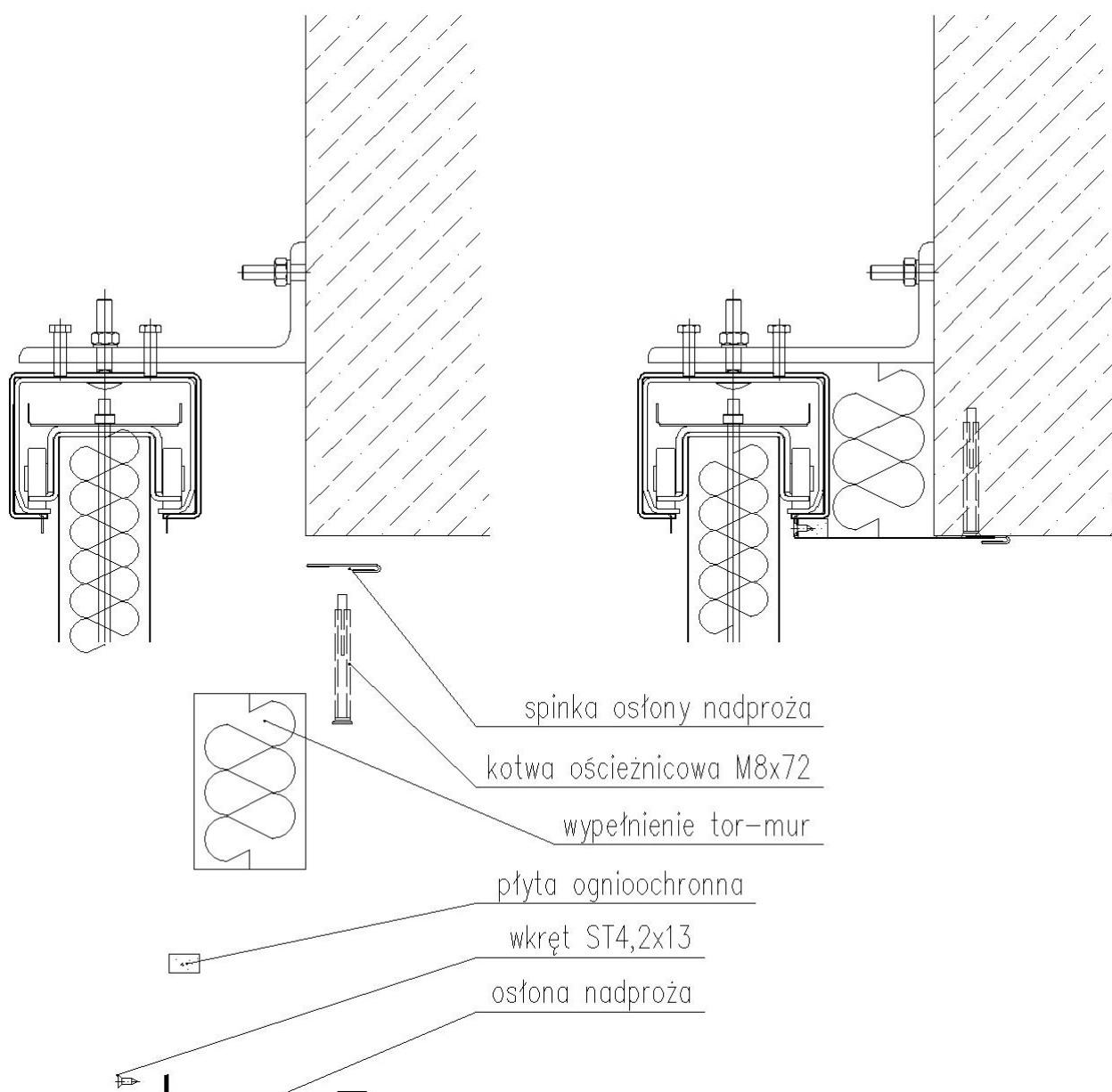

Figure 35: Installing the lintel cover

### 5.9.6. Installing the guide rail cover

- Mount track cover angle bars to wall-mounted supports, using self tapping-screws 4.2x13;
- Fasten the guide rail cover by placing the cover upon the support, and sliding the guide rail together with the firestop plate into the clip;
- The connection of the cover clip with the guide rail fixing metal sheets should be secured against falling off by riveting using rivets 4x10.

**Note:** *Guide rail covers should be installed in the same way for the EI 120 gate; moreover, for the EI120 gate, the guide rail should be secured with flame-retardant elements.*



EI60

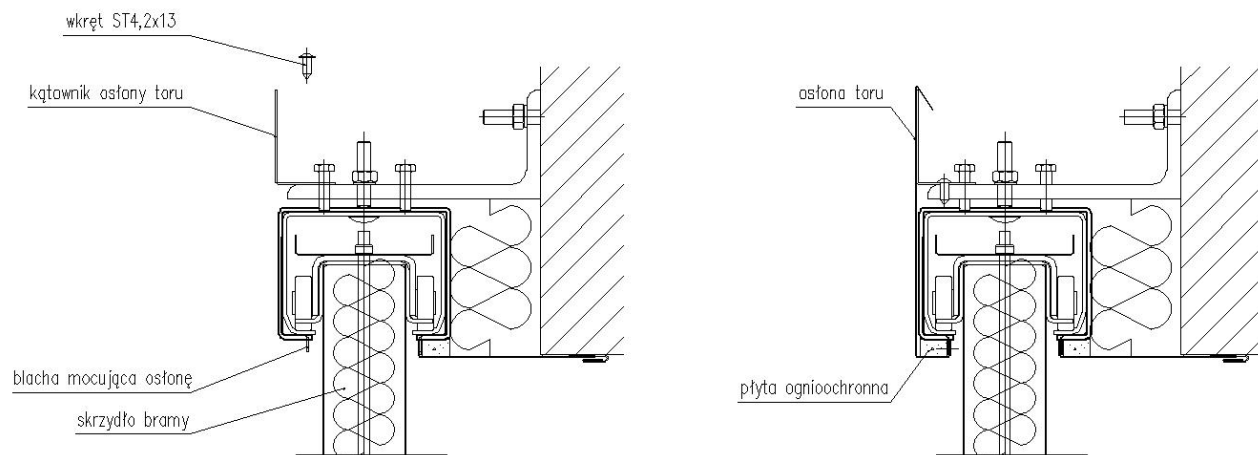

EI120

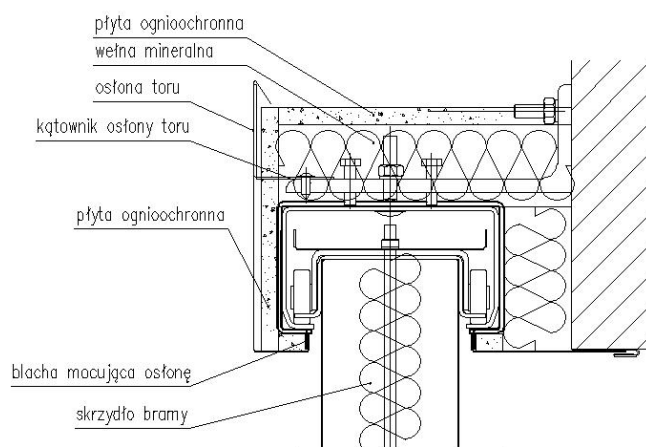

Figure 36: Installing guide rail covers

## 6. Installing the VIC drive

- VIC drive installation should be performed in compliance with a separate Assembly Manual for the VIC Drive.

**Note:** Installation details for the particular types of drive are available in separate Manuals:

Pos. 1,2,3,4 – Assembly Manual for the VIC 0701 Drive

Pos. 5 - Assembly Manual for the VIC 0103-0105 Drive

Pos. 6 - Assembly Manual for the VIC 0701-0110 Drive

**Note:** Below please find some possible configurations of drive positions in relation to the gate.

**Note:** Prior to installing the drive, check the control system on the plate for proper operation.

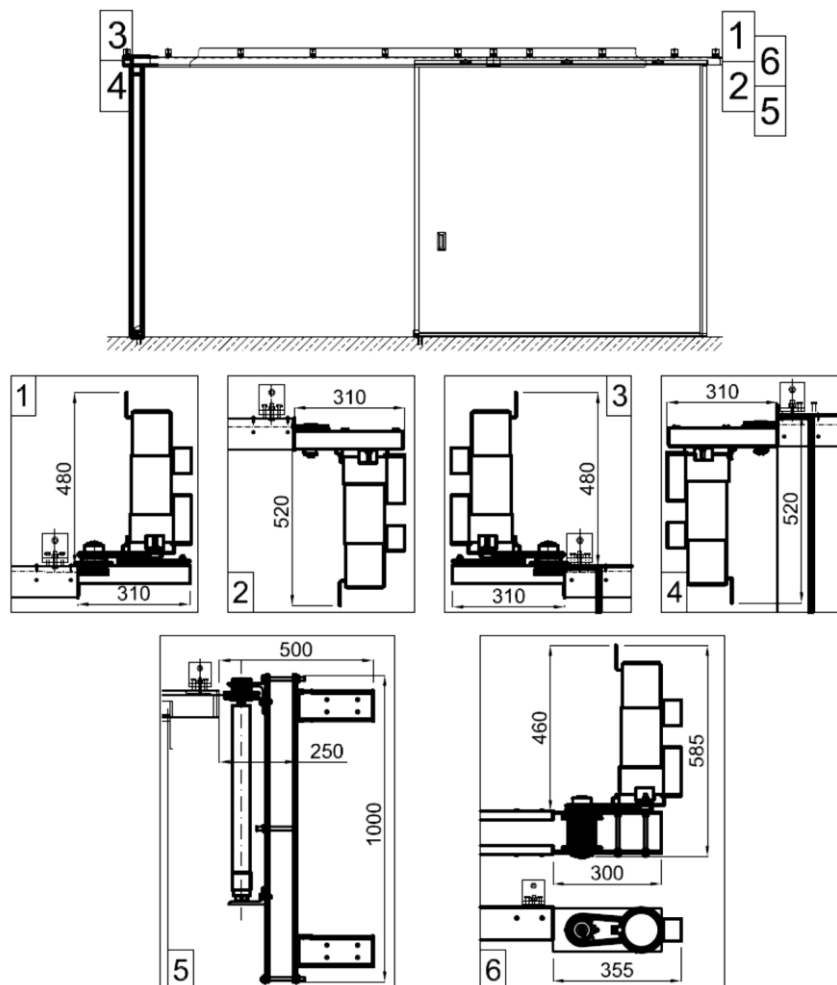

Figure 37: Layout variants of the gate's electric drive



[www.malkowski.pl](http://www.malkowski.pl)