

## Automation for garage & industrial doors

- STRENGTH AND SILENCE;
- INTENSIVE USE;
- ALL COMPONENTS ARE MADE OF STEEL AND BRONZE;
- MOTOR POWER 600 W;
- TORQUE (130 NM);
- MOTOR WITH FAST UNLOCK DEVICE;
- CONTROL PANEL SU INTEGRATED BUTTON.



Technical data	POWER 35
<b>Elektrinė dalis</b>	
Power supply (Vdc)	230
Absorbed current (A)	3,3
<b>Performance</b>	
Speed (m/s)	-
Max thrust (N)	-
Max. Gate size	35 kv. m
<b>Parameters</b>	
Operating temp. (C°)	-20°/+50°
Protection level (IP)	IP 40
Operation cycle	30%
Weight (kg)	14,7

idomus



Functional good looks and dimensions that allow installation in the most difficult places



The mechanical components are all made of metal and submerged in oil in order to ensure a long life of the product.

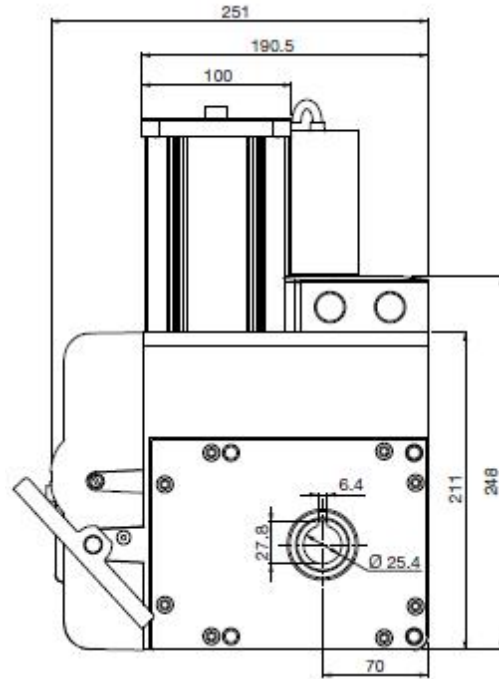
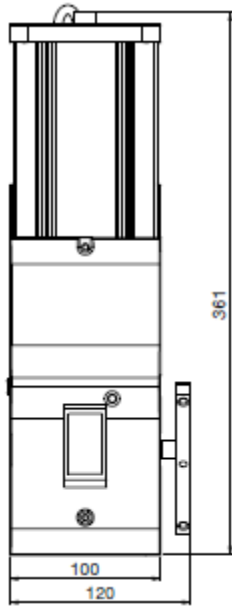

## Accessories



Transmitter  
CLICK 4



LED flashing  
LIGHT 230V/24V



Photocell with sun panel  
GUARD Solar



Photocell  
GUARD