

STARG8 AC

EN Control unit for 230V motor for sliding gates, or for one or two 230V motors for swinging gate

Installation and use instructions and warnings

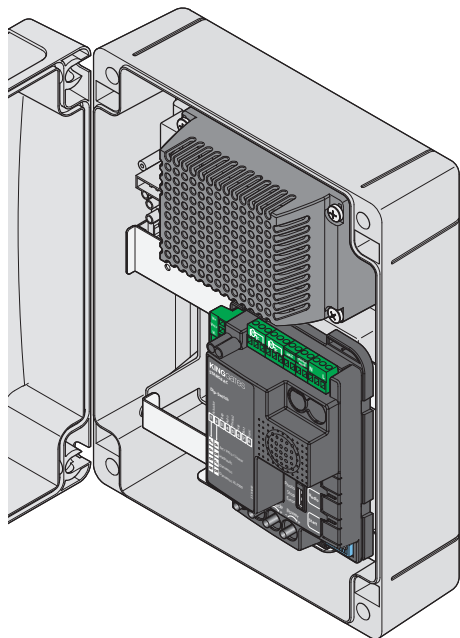

STARG8 AC BOX
Control unit for
Jet 230, Linear 230V or Intro 230-400

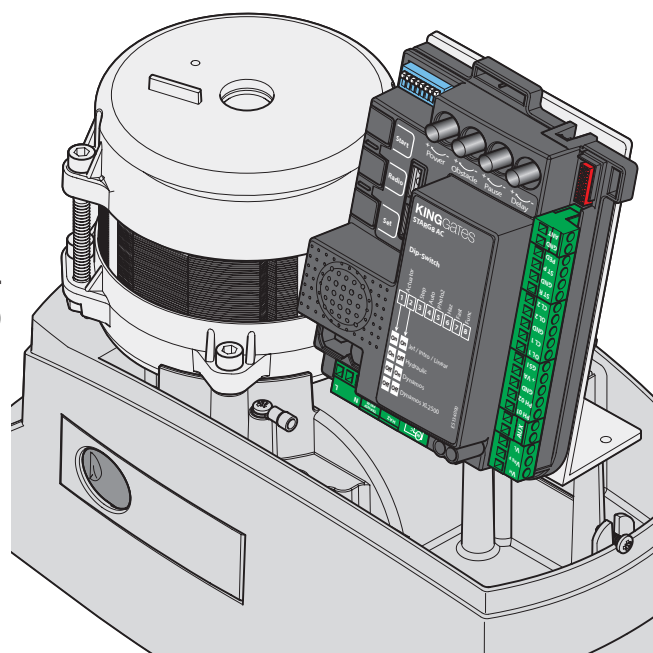

Control unit for
Dynamos 230

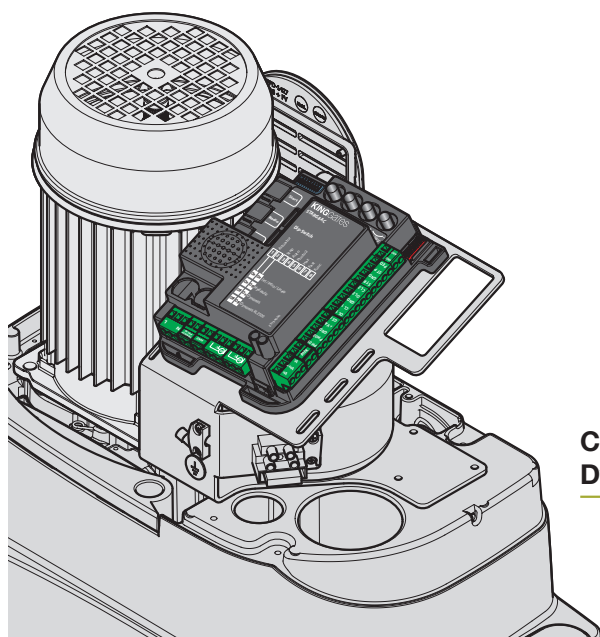

Control unit for
DynamosXL 2500

Contents

1. Product description	1
1.1 - Commissioning	1
1.2 - Main features	1
1.3 - Control unit technical features	1
2. Wiring	2
2.1 - STARG8 AC power connection	2
2.2 - XL motor power connection	3
2.3 - STARG8 AC Accessories wiring connection of a typical system	4
2.4 - STARG8 AC power connection	5
3. Control unit settings	6
3.1 - Dip-switch adjustment	6
3.2 - Trimmer adjustment	7
4. Transmitter programming	8
4.1 - Start button programming	8
4.2 - Pedestrian opening button programming	8
4.3 - Total deletion of memorised transmitters	9
4.4 - Deleting a single transmitter	9
4.5 - Remote transmitter programming	9
5. Programming the gate path	10
5.1 - Basic programming of the automation's movement	10
5.2 - Programming the pedestrian opening width	11
5.3 - Advanced programming of the automation's movement	12
6. Testing and commissioning	13
7. LED signalling	14
7.1 - Input status signalling led	14
7.2 - Error signalling led	14
8. Devices connectable to the PCB	15
8.1 - Line power supply	15
8.2 - Transformer	15
8.3 - Warning light	15
8.4 - Motors	15
8.5 - AUX contact	15
8.6 - Safety devices	15
8.7 - 24 VDC accessory power	17
8.8 - Open gate pilot light	17
8.9 - Limit switches	17
8.10 - Wired commands	17
8.11 - Antenna	17
9. Troubleshooting	18
10. Advanced programming - Index	19

Note: the control unit is equipped with advanced programming features which are not required for commissioning the system but rather for configuring advanced functions (par. 10).

1. Product description

1.1 - Commissioning

To start-up the system, the following steps must be carried out:

- 1 - Connect the power supply, compatible gearmotors (see Paragraph 3.1, dip 1 and 2 setting) and desired accessories as indicated in Paragraph 2.
- 2 - Set the dip switches (par. 3.1) and trimmers (par. 3.2) according to the desired types of operation and the system's structural configuration.
- 3 - Memorise the transmitters (Paragraph 4).
- 4 - Programme the basic gate path (Paragraph 5) so that the control unit learns the manoeuvre's start and end points.
- 5 - Perform the checks described in the "Testing and commissioning" paragraph (Paragraph 6).

⚠ If, after completing these steps, the control unit should malfunction, consult Paragraph 7, "Status signalling LEDs", to identify any anomalies, and Paragraph 9, "Troubleshooting", to attempt to solve them.

1.2 - Main features

- Automated access command for 1 or 2 230V motors.
The dip switches can be used to configure the control unit in relation to the operator.
- Flasher control with/without integrated intermittency function (Paragraph 8.3).
- Integrated management for electric locks 12V max. 15VA or settable to 24V with dedicated programming (Paragraph 8.4).
This output can also be used to control courtesy lights (Paragraph 13).
- Double NC input for opening and closing limit switch (Paragraph 8.9).
- Inputs for start, stop and pedestrian opening wired commands, customisable to open, stop and close (Paragraph 8.10).
- Double input for safety devices: "PHO1" during closing and "PHO2" during closing and/or opening (Paragraph 8.6).

- Possibility of powering 24VDC accessories (Paragraph 8.7).
- Input for gate status pilot light signalling the position of the leaves (Paragraph 8.8).
- Input for external antenna that can be used for increasing the range of the transmitters (Paragraph 8.11).
- Staggered closing of gate leaves adjustable through the trimmer (Paragraph 3.2).
- Pause time for automatic re-closing adjustable to between 0 and 180 sec. with trimmer (Paragraph 3.2).
- Obstacle sensitivity adjustment with trimmer (Paragraph 3.2).
- Motor force adjustment with trimmer (Paragraph 3.2).
- Incorporated radio receiver (433.92MHz), compatible with King-Gates rolling transmitters.
- 6 signalling LEDs (Paragraph 7).
- Slow-speed opening and closing (customisable through dedicated programming).

1.3 - Technical features of the control unit

Mains power supply*	230 Vac \pm 10%, 50 - 60 Hz
Motor power supply	400W 230VAC and 1.7A maximum peak motor
Warning light power supply	230Vac max 15W
Gate pilot lamp power supply	24Vdc max 10 W
Accessories' power supply (photocells...)	24 Vdc max 10 W
Radio receiver frequency	433.920 MHz
Storable remote controls	170
Radio antenna input	RG58
Operating temperature	-20 \div 50 °C

2. Wiring

2.1 - StarG8 AC power connection

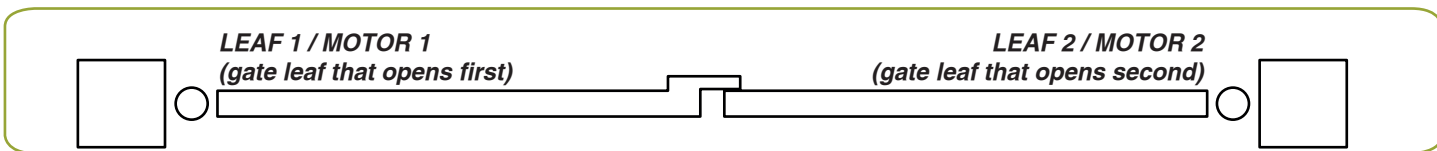
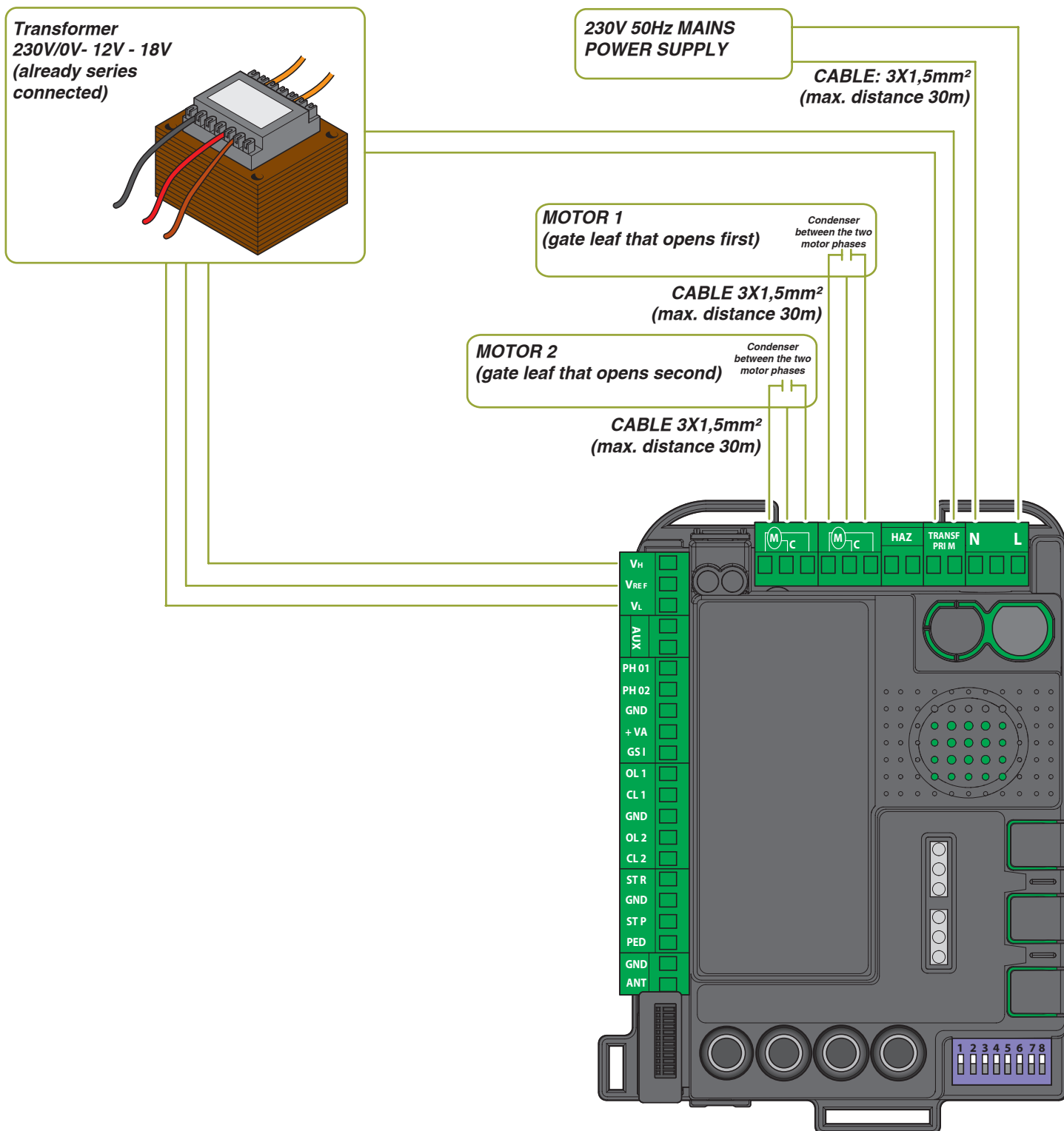

2.2 - XL motor power connection

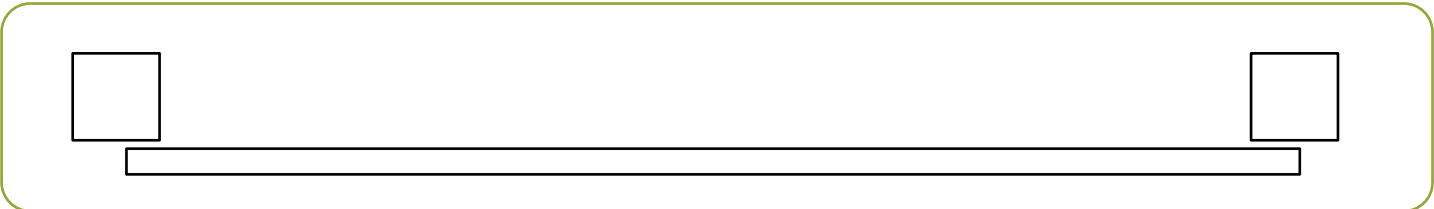
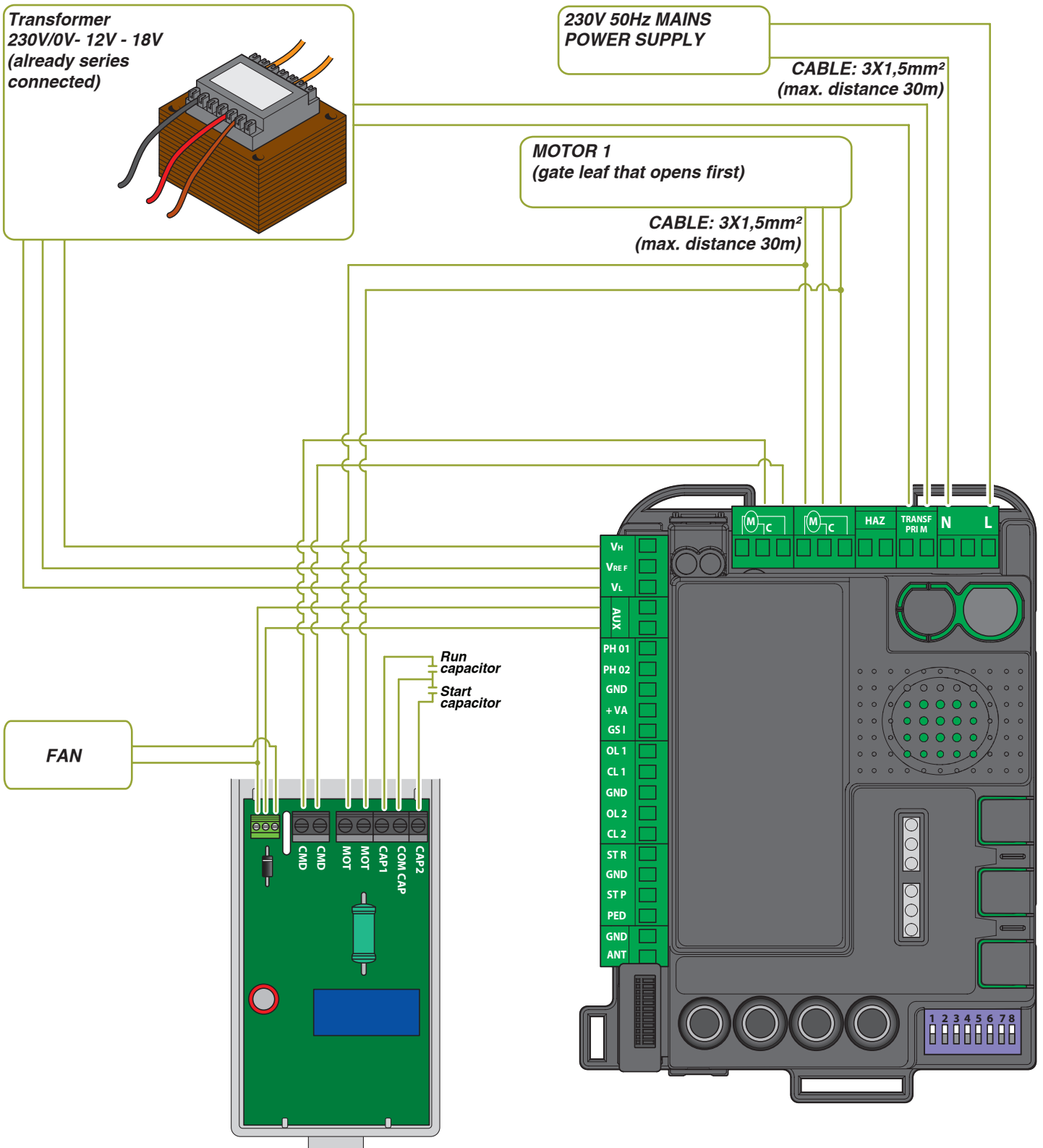

2.3 - StarG8 AC Accessories wiring connection of a typical system

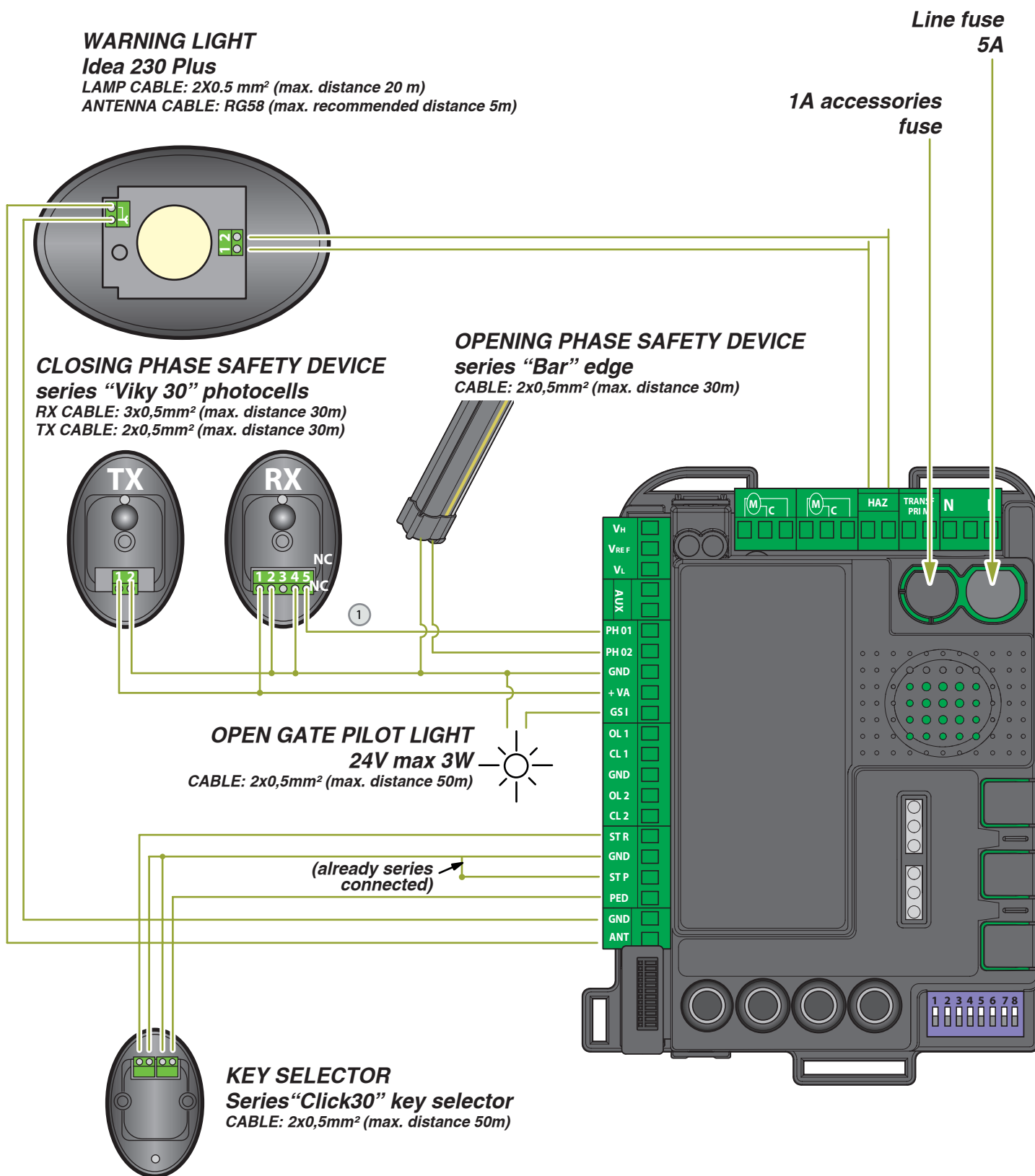

2.4 - StarG8 AC Accessories wiring connection

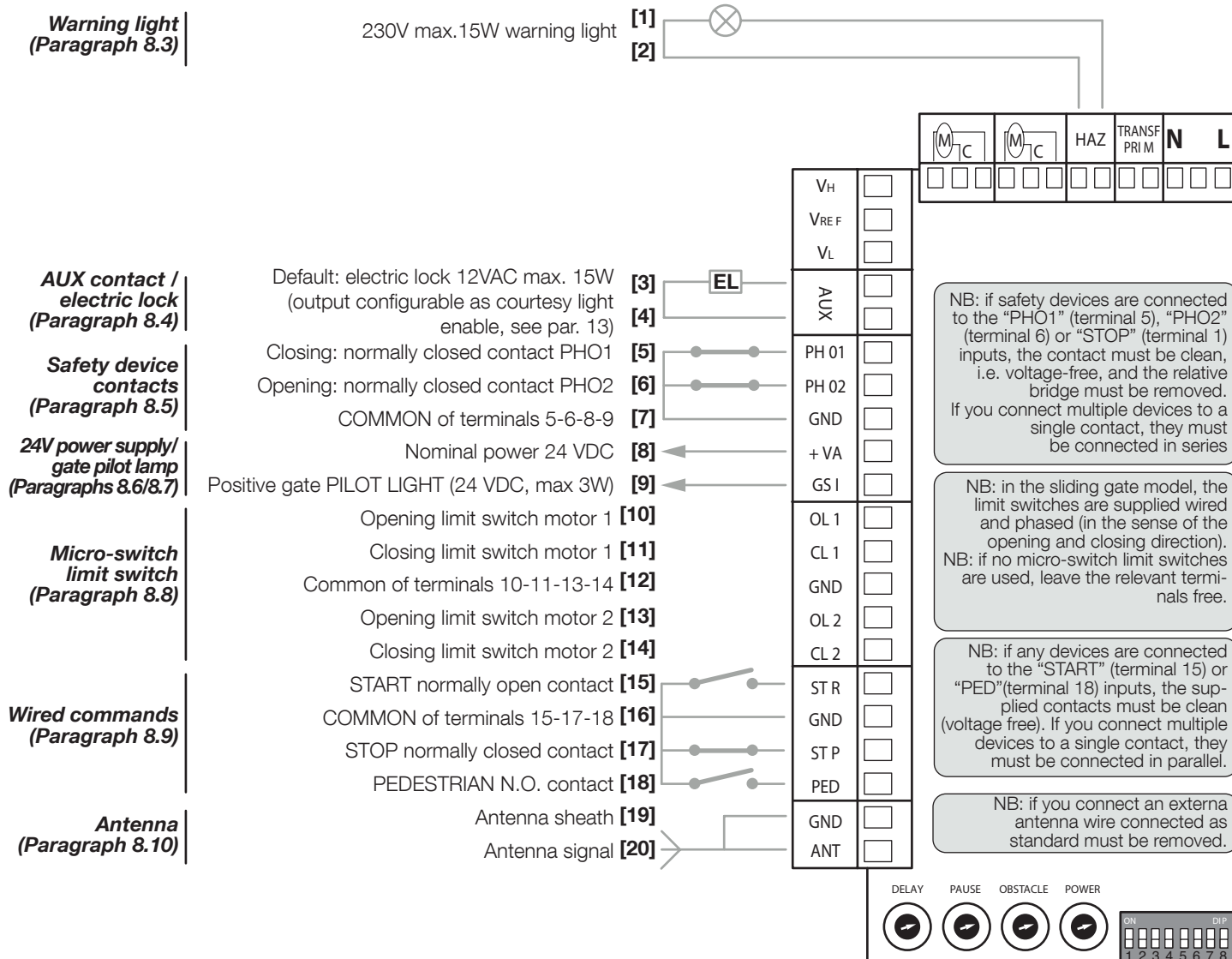

⚠ COMPANY FUNCTION: if, with the automation closed, the START contact is pressed and held closed (for example, through a timer-controlled or bistable relay), the control unit opens the gate and the automation does not accept closing commands (neither automatic nor wired) until the contact is reopened. In this mode, dip3 STEP is usually set to OFF and dip 4 AUTO to ON, to ensure that the gate never remains locked open.

3. Control unit setting

3.1 - Dip-switch adjustment

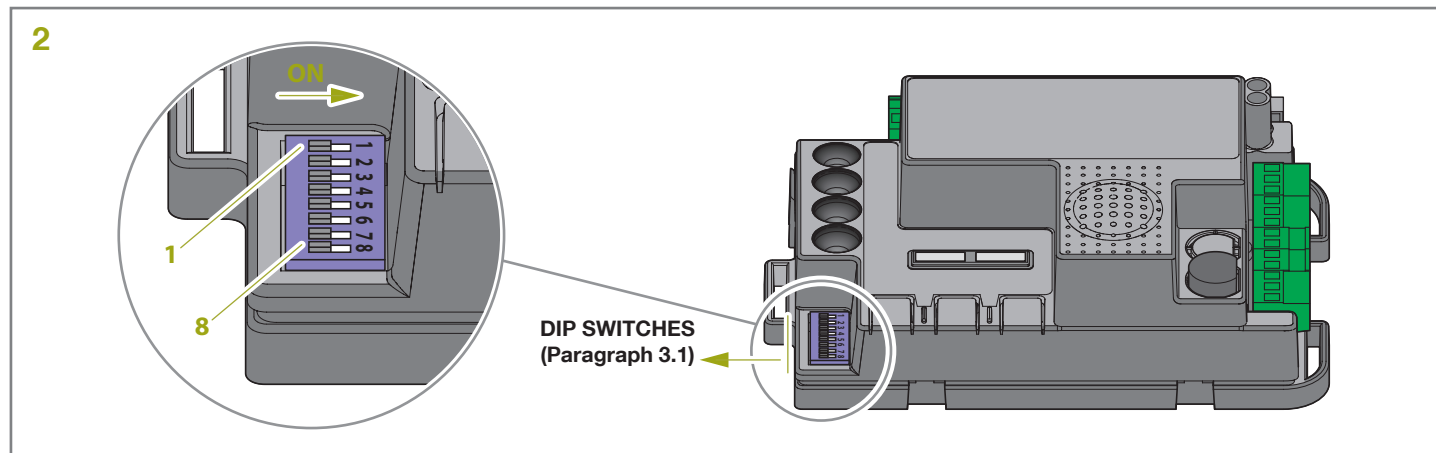

DIP	DIP-SWITCH status		Description of operation
DIP 1-2 MOTOR	ON ON		Connected gearmotors: swinging series: "Jet 230V", "Linear 230V", "Intro 230-400"
	ON OFF		Connected gearmotors: hydraulic
	OFF ON		Connected gearmotor: sliding series "Dynamos 230V"
	OFF OFF		Connected gearmotor: sliding series "Dynamos XL 2500"
DIP 3 STEP	ON		Step-by-step command mode: Open / Stop / Close / Stop
	OFF		Command mode: opening only, if automatic closing is activated
DIP 4 AUTO	ON		Automatic closing activated (time set with the "Pause" trimmer)
	OFF		Automatic closing deactivated
DIP 5 PHO2	ON		Safety devices connected to "PHO2" set as photocells (movement stopped during opening and closing)
	OFF		Safety devices connected to "PHO2" set as edges (reverse of opening movement)
DIP 6 HAZ	ON		Intermittent warning light power supply
	OFF		Fixed warning light power supply
DIP 7 FAST	ON		Immediate re-closing after intervention of "PHO1" photocells
	OFF		No intervention of the photocells during re-closing
DIP 8 FUNC	SWINGING (see DIP 1-2)	ON	Ram function enabled
		OFF	Ram function disabled
	SLIDING (see DIP 1-2)	ON	Reverse opening direction (the system must be programmed afterwards)
		OFF	Reverse opening direction (the system must be programmed afterwards)

⚠ A variation of DIP 1-2 "MOTOR" and DIP 8 "FUNC" (if the control unit is set to sliding gate) will not become effective until a new gate path is programmed (Paragraph 5).

DIP1-2 "MOTOR":

Set **DIP 1** and **2** in relation to the connected gearmotor. Depending on the selected gearmotor, the control unit may set backjumps at the end of the gate's travel and vary the power supply to the motors.

DIP3 "STEP":

If the dip-switch is put to **ON**, the step-by-step operating mode is activated. At every start pulse (wired or via transmitter), the control unit performs an action. Starts the motor if the automation system is stopped, and stops it if it is moving. If the **"STEP"** dip-switch is put to **OFF**, the OPEN FULLY/PAUSE/CLOSE FULLY/STOP operating mode is activated (apartment block). The control unit only accepts commands (either wired or via transmitter) for the opening phase. Starts again from zero with the set delay when the automation system is open. With the automation in the opening phase, it continues

to open, and with the system in the closing phase it reopens fully. The automation can re-close with the time set through the **"PAUSE"** trimmer, if the **"AUTO"** dip-switch is set to **ON**. If not, it is necessary to give a START command (either wired or via transmitter) with the automation fully open.

DIP4 "AUTO":

If the dip-switch is put to **ON**, the automatic re-closing function is activated. The control unit automatically closes the leaves after the time set through the **"PAUSE"** trimmer (see Paragraph 3.2). If the **"AUTO"** dip-switch is put to **OFF**, the automatic re-closing function is deactivated. To close the leaves, therefore, a command must be given (either wired or via transmitter).

DIP5 "PHO2":

If the dip-switch is put to **ON**, the safety devices for the opening phase (see Paragraph 8.6) are set as photocells: they intervene during both the opening and closing phases, by locking the movement of the leaves and resuming the movement once they are released.

If the “PHO2” dip-switch is put to **OFF**, the safety devices for the opening phase (see Paragraph 8.6) are set as edges: they intervene only during the opening phase by inverting the movement (thus closing the gate fully). The safety devices for the closing phase do not intervene.

DIP6 “HAZ”:

If the dip-switch is put to **ON**, the warning light is powered (terminals 1, 2) in the intermittent mode. If the “HAZ” dip switch is set to **OFF**, power to the flasher is constant (terminals 1 and 2).

DIP7 “FAST”:

If the “FAST” dip-switch is put to **ON**, the rapid re-closing function is activated. This mode closes the gate as soon as the control unit sees that the photocells (if any) connected to the “PHO1” input are obscured and cleared (regardless of any other settings). Therefore, leaving (or entering from) the gate causes the automation to immediately re-close without waiting for the pause time.

If the “FAST” dip-switch is put to **OFF**, the rapid re-closing function deactivates.

DIP8 “FUNC”:

SWING GATE (DIP1/2= ON ON / ON OFF/ OFF OFF)

If the “FUNC” dip switch is set to **ON** this activates the ram function, which is advisable if an electric lock is installed (see par. 8.5). This delivers a transient voltage peak at the start of the opening stroke and the end of the closing stroke to overcome the resistance of the pawl.

If the “FUNC” dip switch is set to **OFF** the ram function is disabled.

SLIDING GATE (DIP1/2= OFF/ON)

Changing the position of the “FUNC” dip switch changes the opening stroke direction. This is read only at the beginning of basic or advanced programming.

3.2 - Trimmer adjustment

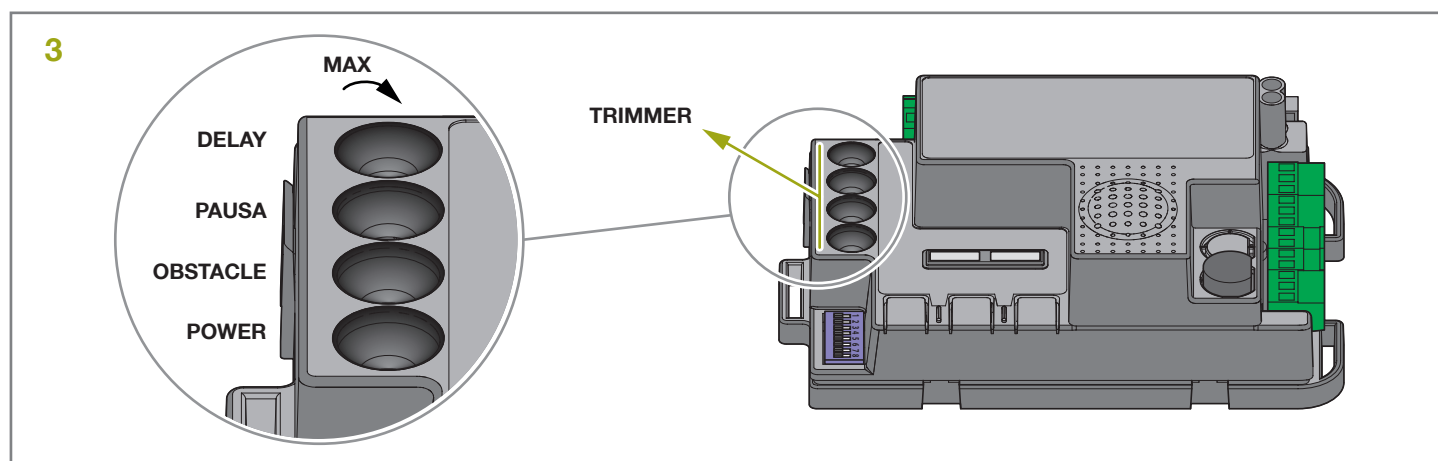

Trimmer	Description
POWER	Power: adjustment of motor power. Turning the trimmer clockwise increases the motor's power. To validate the modification it is necessary to programme the gate path..
OBS	Obstacle, sensitivity to obstacles: adjustment of the obstacle detection function. Turning the trimmer clockwise increases the drive time before obstacle detection (less sensitivity). Therefore, in systems with particularly unfavourable mechanical conditions, it is advisable to keep the drive time high.
PAUSE	Pause time before automatic gate closing. Turning the trimmer clockwise increases the pause time from 0 to 180 seconds. Please note: the AUTO dip-switch must be put to ON.
DELAY	Staggered closing of the gate leaves: In case of two connected motors, it adjusts the staggering of the leaves. Turning the trimmer clockwise increases the stagger time from 0 seconds until complete staggering.

⚠ Varying the “POWER” trimmer has no effect until the stroke is reprogrammed (par. 5).

⚠ In normal operation, if the “delay” trimmer is set to too low a value (not “zero”: the gate sections must be offset to prevent them overlapping) and section 1 arrives before section 2, the control unit will automatically open the gate slightly and the close the sections in the correct order (anti-overlapping mechanism).

4. Transmitter programming

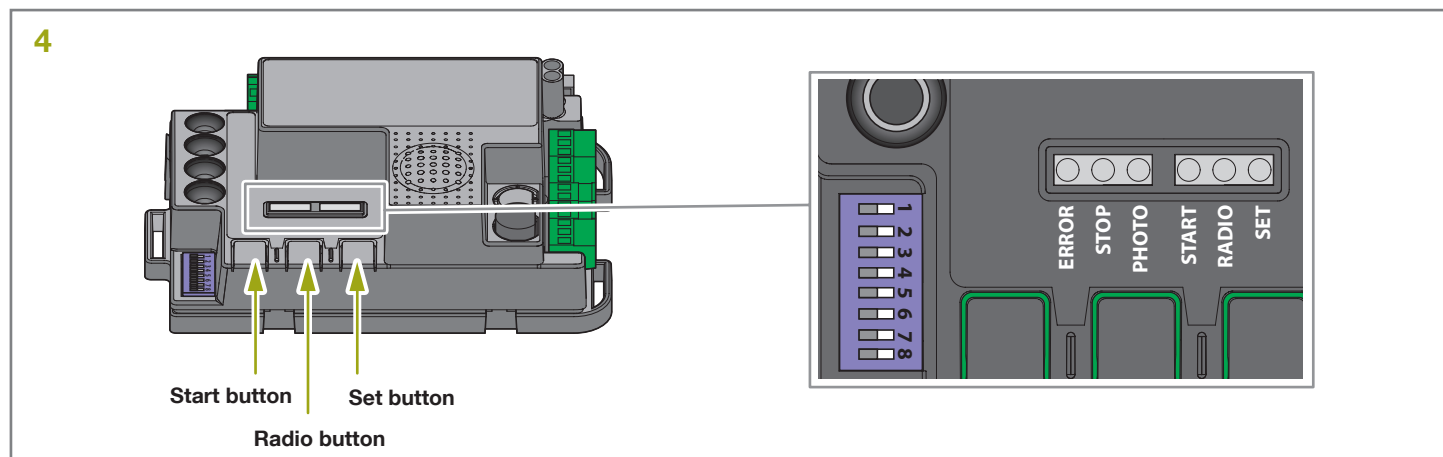

⚠ The transmitters to be programmed must be of the “Stylo4K” or “Stylo2K” series by King Gates. See adjacent pictures.

⚠ If, at the start of the following procedures, the “set”, “radio” and “start” LEDs flash, it means that the programming protections have been activated – see Paragraph 16.1.

⚠ To interrupt the following programming procedures at any time, press the SET and RADIO buttons simultaneously or wait 10 seconds

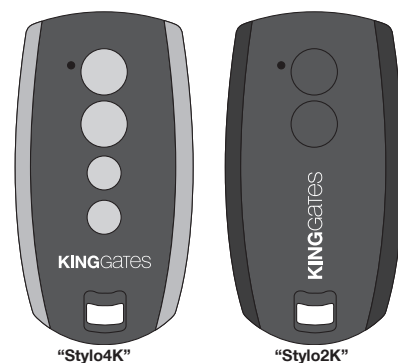

4.1 - Start button programming

This procedure allows for programming the button of the radio control linked to the automation’s start function.

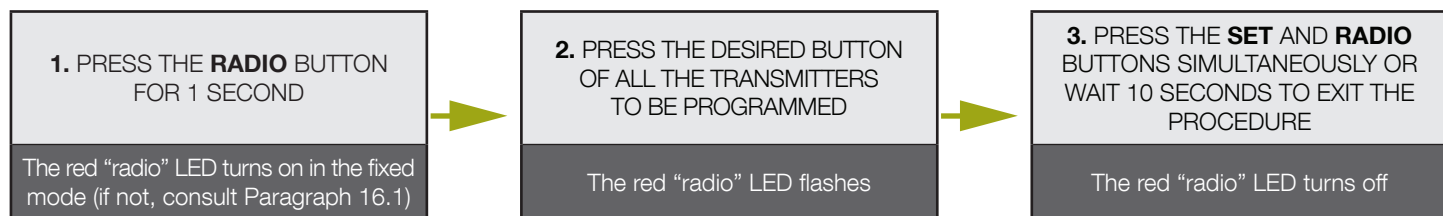

4.2 - Pedestrian opening button programming

This procedure allows for programming the button of the radio control linked to the automation’s partial opening. The broadness of the pedestrian opening can be customised through the procedure described in Paragraph 5.2.

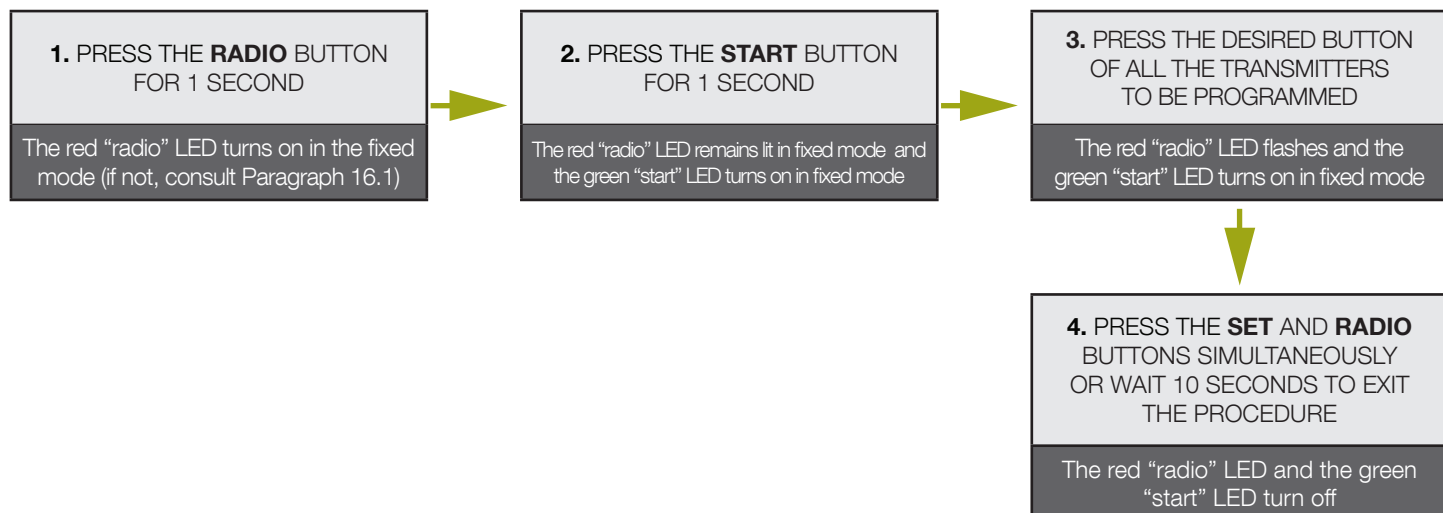

4.3 - Total deletion of memorised transmitters

This operation deletes all memorised transmitters

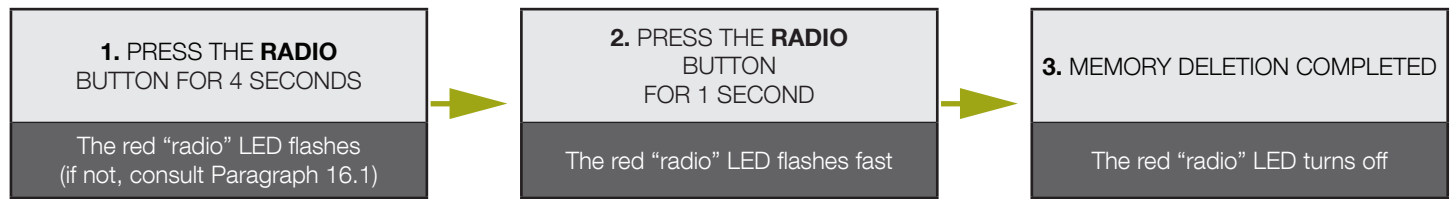

4.4 - Deleting a single transmitter

This operation deletes a single transmitter from the memory.

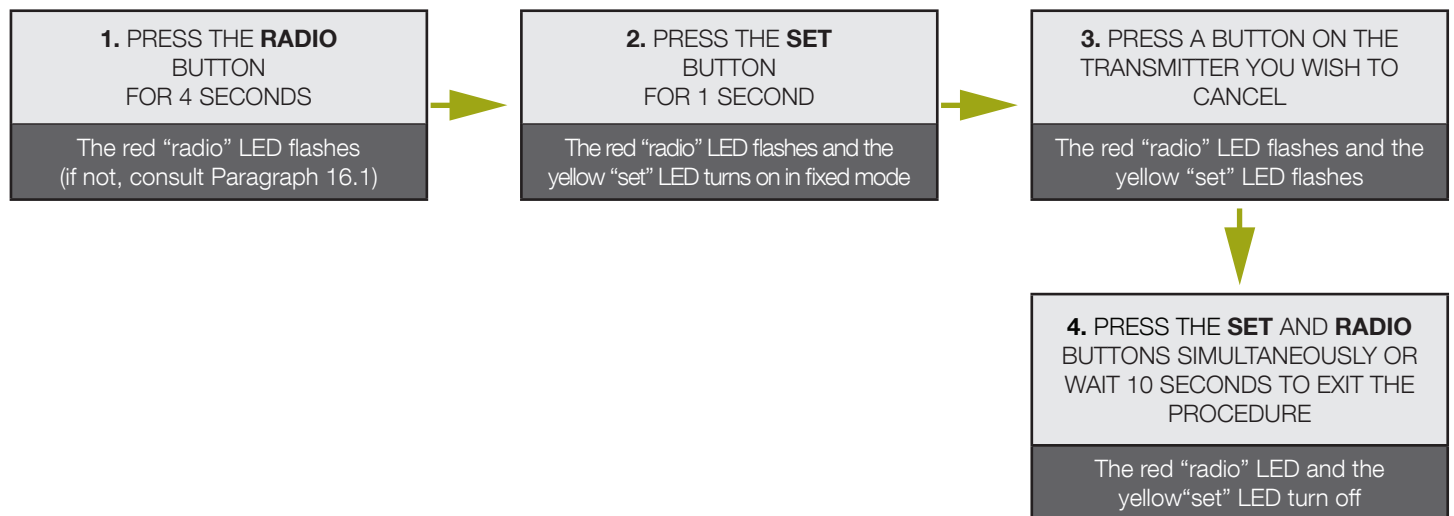

4.5 - Remote transmitter programming

This procedure enables you to program a new transmitter ("Stylo2K" or "Stylo4K") without accessing the control unit, but keeping close to it. To run the procedure you will require a previously programmed transmitter, to copy its functions.

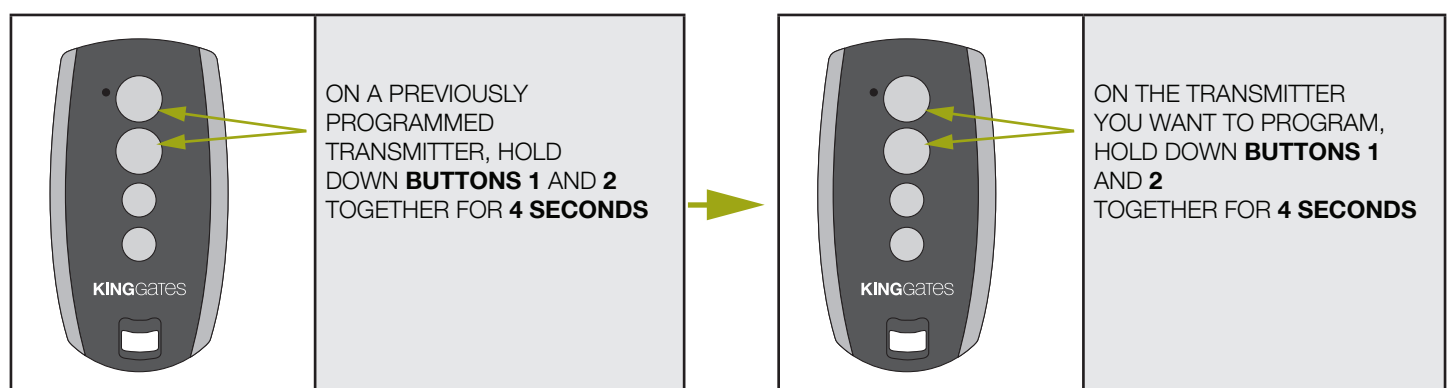

5. Programming the gate path

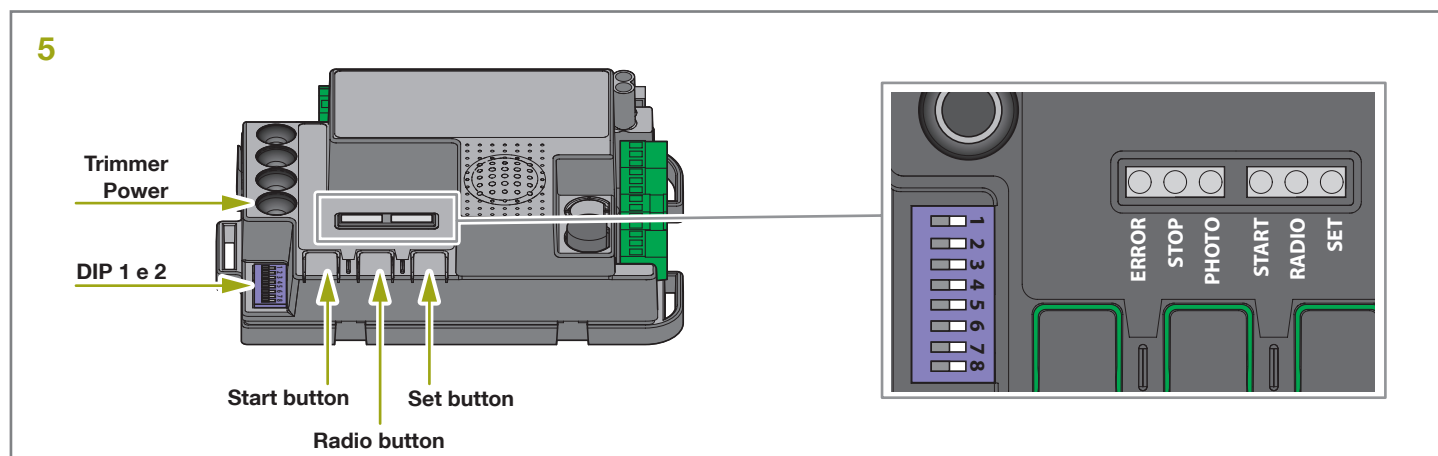

To start the system up, one of the following programming procedures must be carried out:

- basic programming of the automation's movement: self-learning of the manoeuvre times and of the slowdown start points.
- advanced programming of the automation's movement: self-learning of the manoeuvre times and manual setting of the slowdown start points.

The procedure for programming the partial opening is used to modify the default opening value.

⚠ If, at the start of the following procedures, the "set", "radio" and "start" LEDs flash, it means that the programming protection has been activated – see Paragraph 16.1.

⚠ To interrupt the following programming sequences at any time, press the SET and RADIO buttons simultaneously or wait 10 seconds.

5.1 - Basic programming of the automation's movement

Through this procedure, the control unit memorises the times and power required for opening and closing the system. In the case of automations for double-leaf gates, the control unit causes the full opening and closing of one gate leaf at a time. The slowdown points are automatically set to 85% of the opening and closing path.

⚠ Prior to proceeding with the programming procedure, verify that dip-switches 1 and 2 have been correctly set.

DIP	DIP-SWITCH status	Description of operation
DIP 1-2 MOTOR	ON ON	Connected gearmotors: swinging series: "Jet 230V", "Linear 230V", "Intro 230-400"
	ON OFF	Connected gearmotors: hydraulic
	OFF ON	Connected gearmotor: sliding series "Dynamos 230V"
	OFF OFF	Connected gearmotor: sliding series "Dynamos XL 2500"

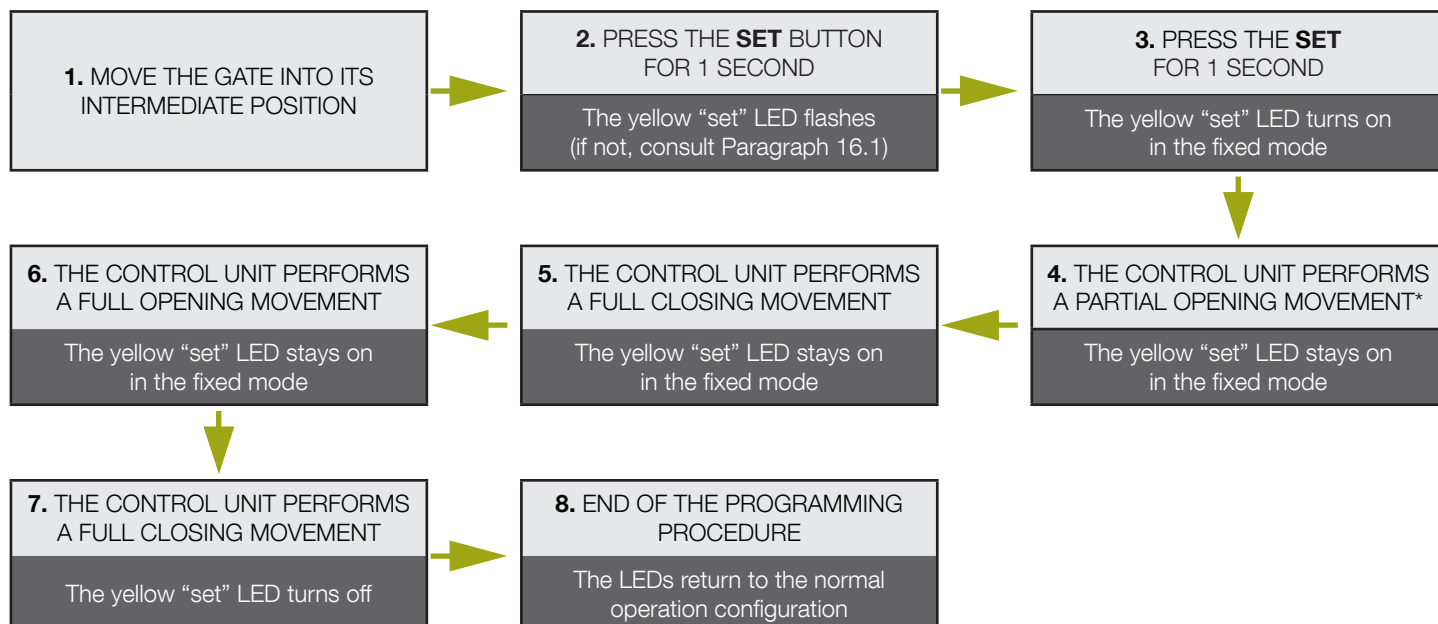

CAUTION! - if the automation starts a closing stroke instead of an opening stroke, proceed as follows:

1. quit programming by pressing **SET** and **RADIO** at the same time:

for **SWING GATE MOTORS**: swap the motor phases (terminals **MOT1**, **MOT2**) and the inputs of any limit switches (terminals 10-11, 13-14) for **SLIDING GATE MOTORS**: change the setting of **DIP8**, see par. 3.1

2. reprogram the stroke from point 1.

⚠ If the operator does not recognise the mechanical stops even with the **OBS** trimmer set to its minimum, you can select the open and closed points during programming by pressing the “**SET**” button at the end of points 5, 6 and 7. If the gate has two sections, use the “**SET**” button for both sections.

5.2 - Programming the pedestrian opening width

This procedure allows for defining the width of the pedestrian opening.

Default: it is set as fully open of **MOTOR1** for swing gate motors and 30% of the stroke for sliding gate motors (see dip-switches 1 and 2 for setting the motor type).

To control the pedestrian opening, it is necessary to either programme a radio control button (see Paragraph 4.2) or connect a wired control device on the “**PED**” contact (see Paragraph 2.2).

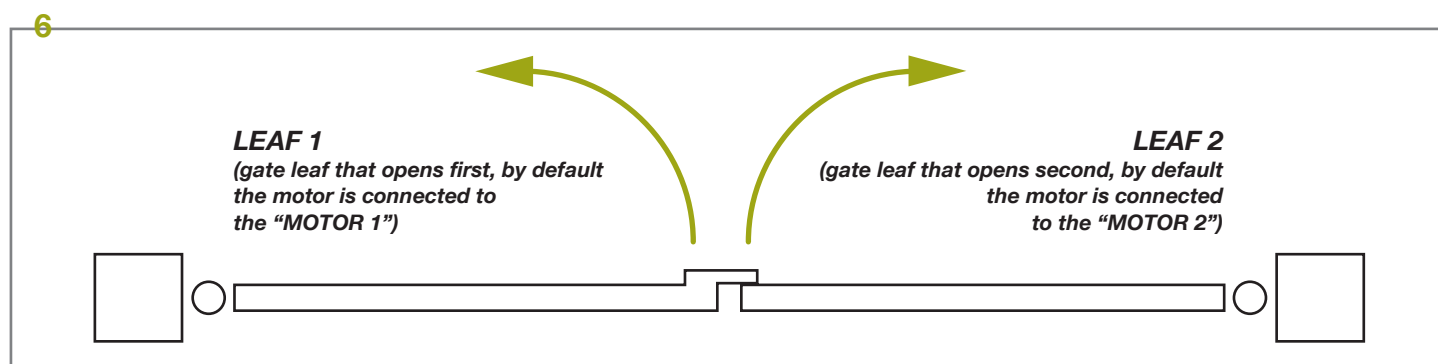

⚠ Prior to proceeding with this programming procedure, first verify whether either the “basic automation movement programming” or the “advanced programming” have been completed.

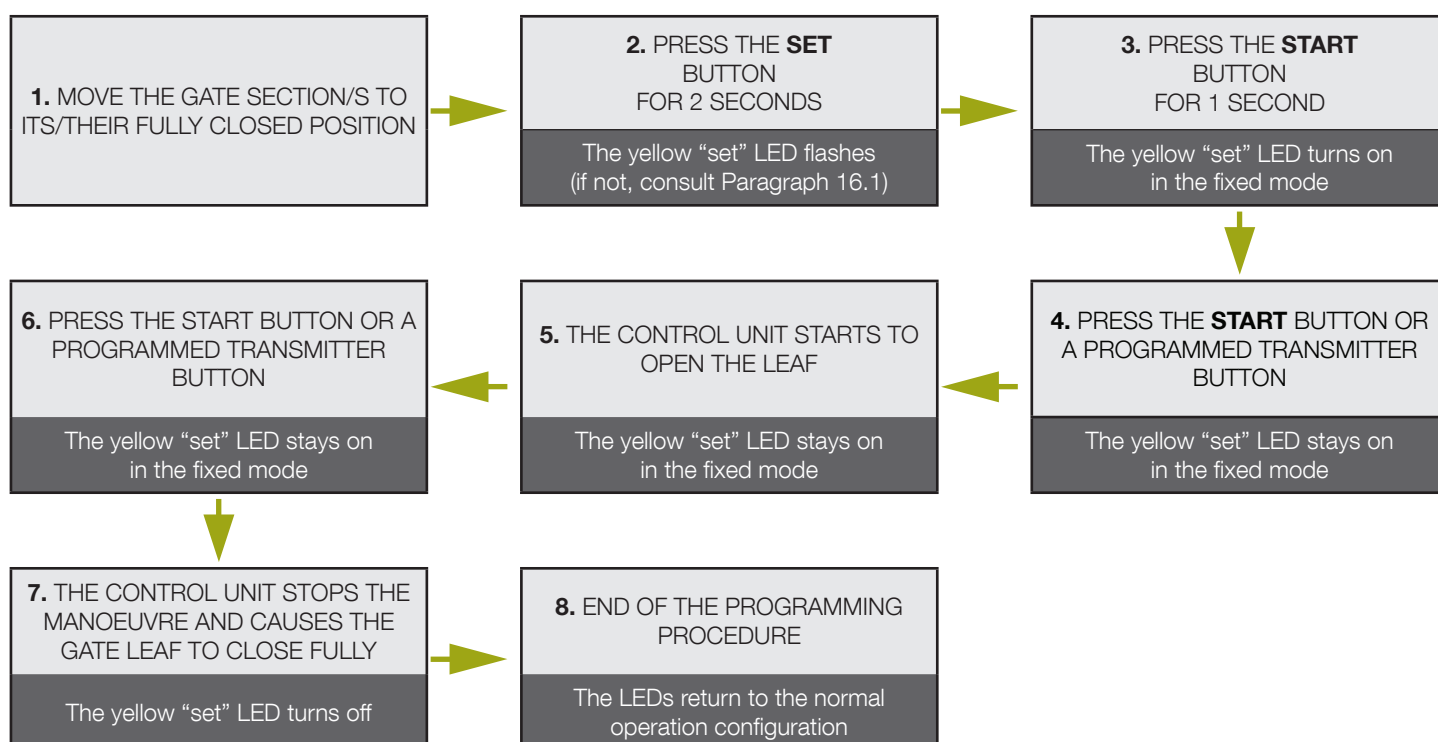

5.3 - Advanced programming of the automation's movement

With this procedure, the control unit memorises the times and power required for opening and closing the system.

Moreover, this procedure allows for setting:

- start point of gate deceleration area or its deletion
- reverse direction of travel

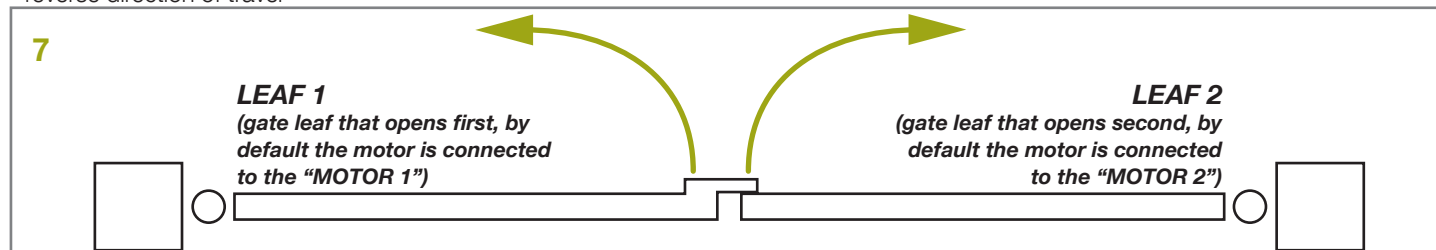

⚠ Prior to proceeding with the programming procedure, verify that dip-switches 1 and 2 have been correctly set.

⚠ Once programming is complete, the reverse motor direction settings will remain in force until the control unit is reset or professionally reprogrammed.

DIP	DIP-SWITCH status	Description of operation
DIP 1-2 MOTOR	ON ON	Connected gearmotors: swinging series: "Jet 230V", "Linear 230V", "Intro 230-400"
	ON OFF	Connected gearmotors: hydraulic
	OFF ON	Connected gearmotor: sliding series "Dynamos 230V"
	OFF OFF	Connected gearmotor: swinging series "Dynamos XL 2500"

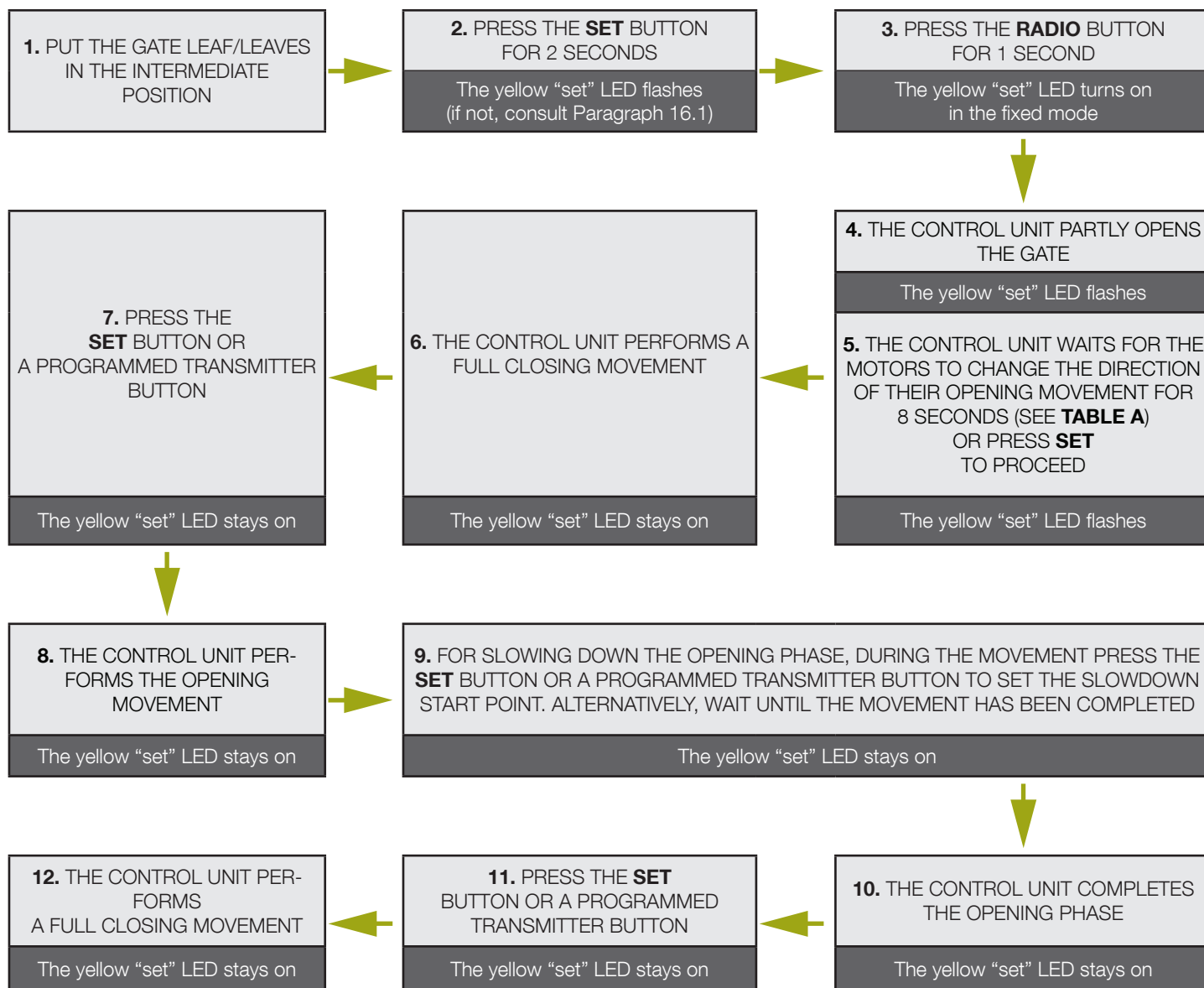

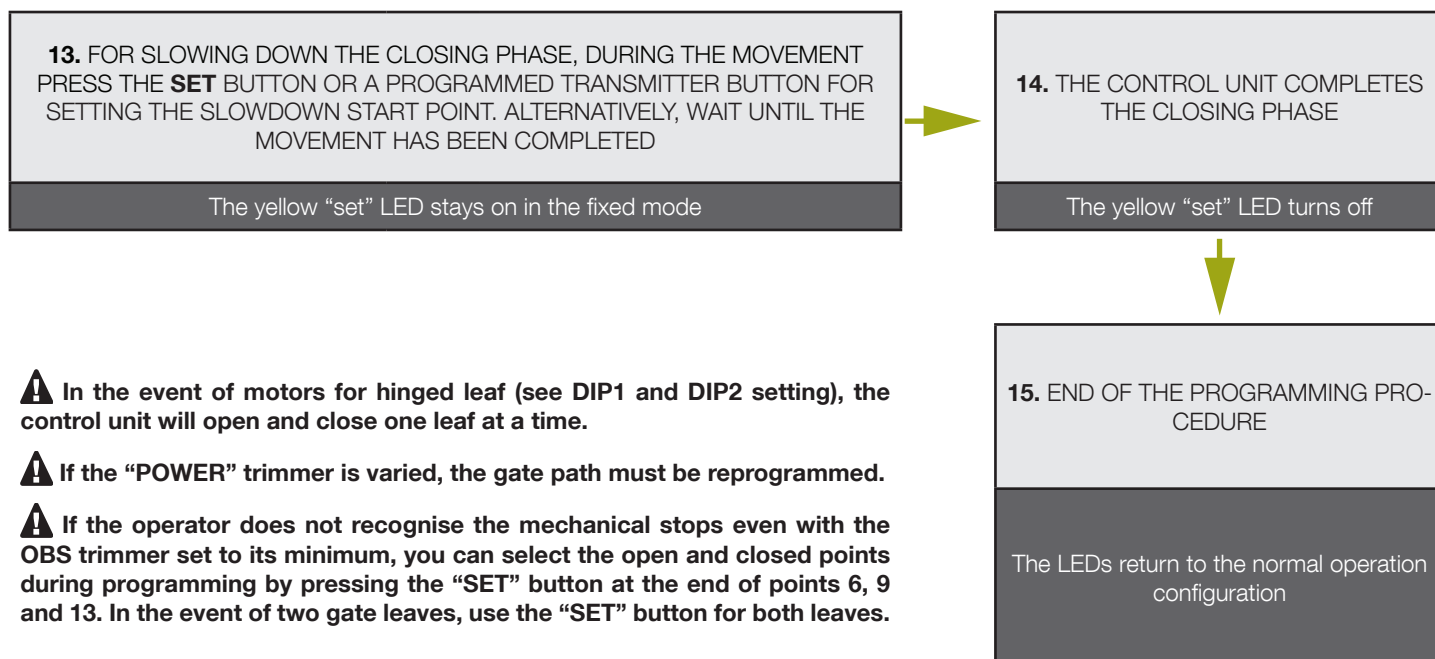
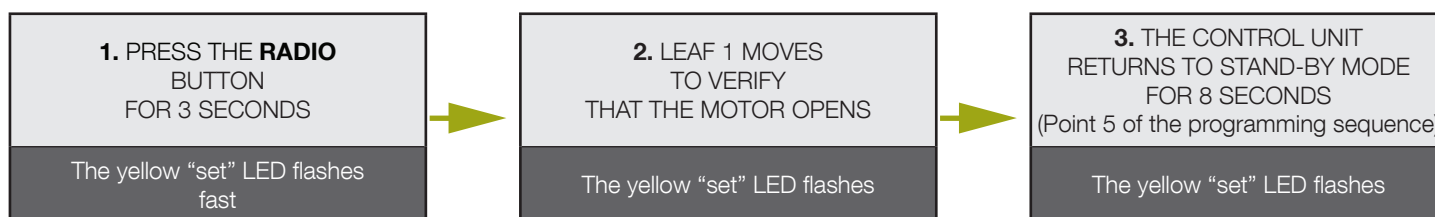
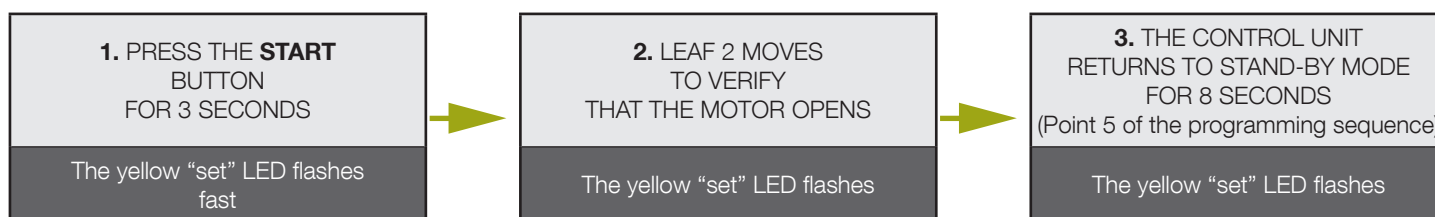

TABLE A

Procedure 1: REVERSING THE DIRECTION OF THE GATE SECTION 1 OPENING STROKE



Procedure 2: REVERSING THE DIRECTION OF THE GATE SECTION 2 OPENING STROKE



6. Testing and commissioning

Once the programming sequence has been completed, verify that:

- the motors switch off after a few seconds once the opening or closing phases end;
- the control unit responds to any and all wired commands: "START" (terminal 15), pedestrian opening (terminal 18) and "STOP" (terminal 17);
- the control unit responds to any programmed radio controls;
- the safety devices connected to "PHO1" (terminal 5) intervene while the gate closes and prevent the open gate from closing;
- the safety devices connected to "PHO2" (terminal 6) intervene while the gate opens and prevent the closed gate from opening;

If the "PHO2" dip-switch is put to ON, check that they intervene also when the gate closes and that they prevent the open gate from closing.

7. LED signalling

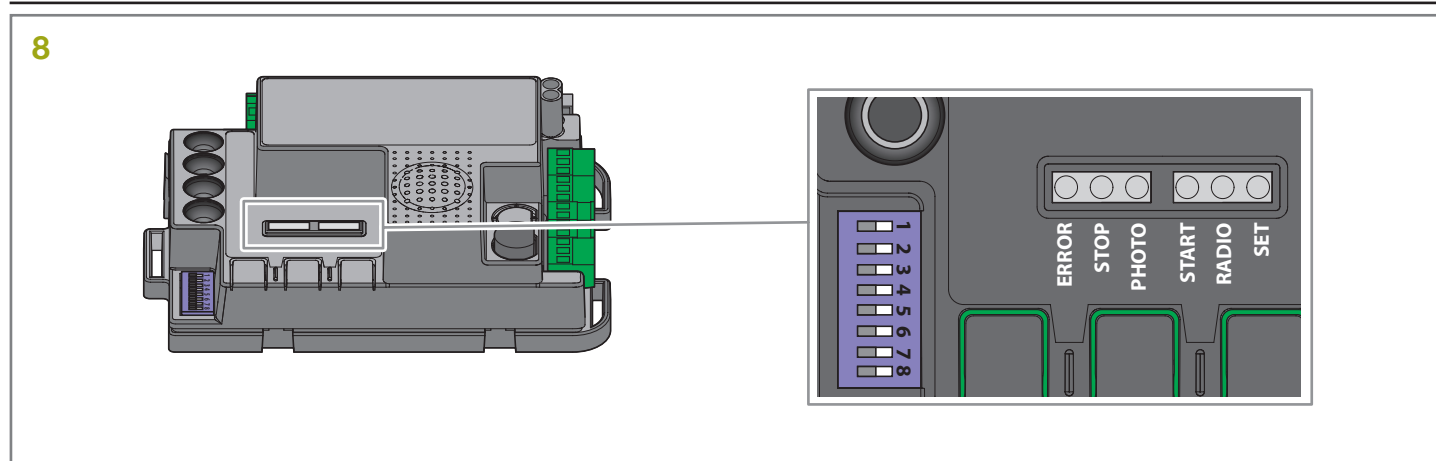

With the control unit powered up (if control unit protection is not activated) the yellow **Set** led flashes for 5 seconds and, if everything is correctly hooked up, the red “**Photo**” and “**Stop**” leds turn on to indicate that the two safety contacts are closed. The yellow Set **LED** is exclusively reserved for programming.

7.1 - Input status signalling LEDs

The following signals refer to the control unit in standby mode, that is, powered and inactive for 12 seconds (not during programming).

GREEN PHOTO LED:

- on in the fixed mode if the PHO1 and PHO2 contacts (terminals 5-6-7) are closed
- off if at least one of the PHO1 or PHO2 contacts (terminals 5-6-7) is opened

GREEN STOP LED:

- on in the fixed mode if the STOP contact (terminals 16-17) is closed
- off if the STOP contact (terminals 16-17) is open

GREEN START LED:

- on in the fixed mode if the START contact (terminals 15-16) is closed
- off if the START contact (terminals 15-16) is open

RED RADIO LED:

- flashes when a command is received through King Gates transmitter
- is off when the control unit is in standby mode

7.2 - Error signalling LEDs

RED “ERROR” LED:

The red “error” LED signals any errors that hamper the correct operation of the PCB.

With the control unit in standby mode, the error type is signalled with a series of flashes at regular intervals (1-second pause between two successive series) according to the following scheme:

Number of flashes per series	Error description
1	On-board memory damaged.
2	Photo-test of safety devices failed. See Paragraph 14.1 for solving the problem.
3	Path programming requested. See Paragraph 5
4	Input “PHO2” set as a resistive edge and check failed. See Paragraph 14.3 for solving the problem.

GREEN START LED:

If, when START on the board is pressed or a control signal is sent by wire, the green led flashes three times without the system executing the manoeuvre, then “wire controls blocked” is enabled: see par. 15.2.

GREEN START LED, RED RADIO LED AND YELLOW SET LED:

If, when attempting to enter into any programming scheme, the set, radio and start LEDs flash fast three times, it means that the “control unit protection” is active. See Paragraph 16.1 for solving the problem.

8. Devices connectable to the PCB

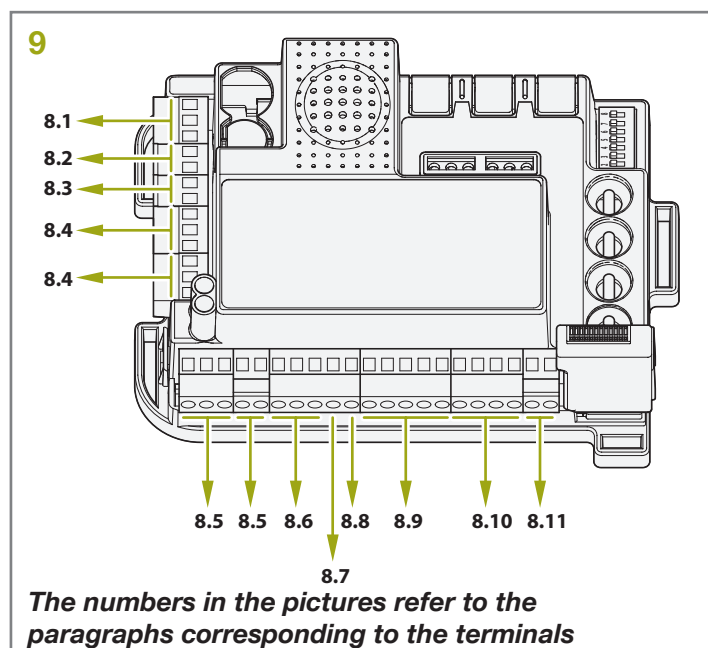

The control unit is prearranged for interfacing with different devices dedicated to system control, system safety and other additional functions. Below is a list of their connections and corresponding functions.

8.1 - Line power supply

The “L” and “N” inputs are prearranged for the line voltage connection. This must be 230Vac 50Hz.

8.2 - Transformer

The transformer is supplied and connected. It has a 230Vac* primary winding and a twin secondary winding of 0 - 12 - 18 Vac.

The power depends on the connected motor.

8.3 - Warning light

DEDICATED TERMINALS: 1-2 (see Paragraph 2.4).

The warning light is an accessory used for signalling any movement of the gate leaf.

The connected lamps must have 230V with 15W maximum power.

Thanks to the “HAZ” dip-switch 6 (see Paragraph 3.1), the control unit can supply oscillating or continuous voltage based on the warning light connected (with or without integrated oscillating circuit)

8.4 - Motors

DEDICATED TERMINALS: sliding = see Paragraph 2.1 / 2.2

swinging = see Paragraph 2.1 / 2.2

In the sliding gate model, the motor is supplied wired and phased (in the sense of the opening and closing direction) with the limit switch connections. The control unit is configured for controlling 1 sliding gate motor or 1 or 2 swinging gate motors (in the case of a sliding gate motor, it must be connected to “MOTOR 1”).

8.5 - AUX contact

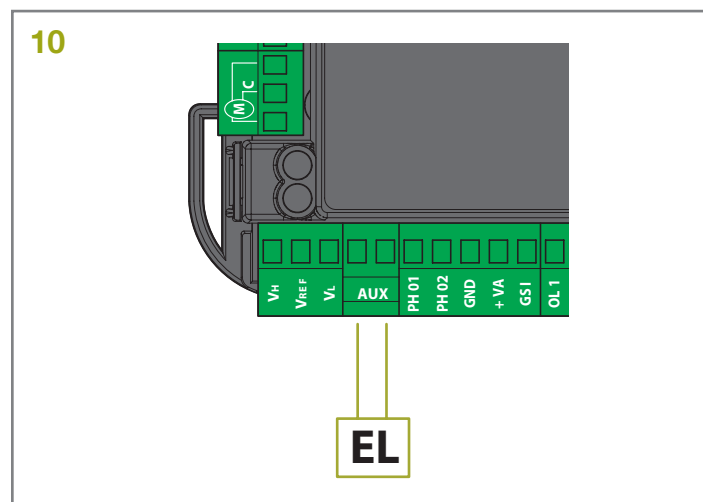

⚠ If the installation includes an electric lock, we recommend enabling the ram function by setting dip switch 8 to ON.

DEDICATED TERMINALS: 3-4 (see Paragraph 2.4). Default setting: electric lock operation.

By default, the AUX contact is able to control an electric lock (customisable as courtesy light) with 12V, by giving a 2-second pulse for every movement command received from the control unit.

However, this output can be customised with the advanced programming functions mentioned in Paragraph 13:

- Selection of AUX output type (Paragraph 13.2) = the output can be set as a lock or courtesy light.
- Selection of AUX operating mode (Paragraph 13.3) = allows for customising the contact’s operation.

8.6 - Safety devices

DEDICATED TERMINALS: 5-6-7 (see Paragraph 2.4).

The control unit contains two outputs for connecting clean contacts for protecting the gate leaf’s movement area.

“PHO1” CLOSING PHASE SAFETY DEVICES

It is possible to connect devices (e.g. photocells or edges with microswitches) with normally closed (NC) contact to the “PHO1” input (terminal 5-7). To ensure correct operation of the accessories, eliminate the standard supplied connection.

These devices intervene during the gate’s closing phase.

In particular:

- during the closing phase they invert the movement direction and re-open the gate fully;
- during the opening phase they have no effect;
- with the gate closed they do not intervene;
- with the gate open they lock the closing commands.

Figures 11a, 11b and 11c show examples of King Gates “Viky30” photocell installations.

⚠ If multiple devices are connected on this contact, they must be series connected (see Fig. 11c).

⚠ If one or more photocell pairs are connected, the receivers must be alternated (see Fig. 11c).

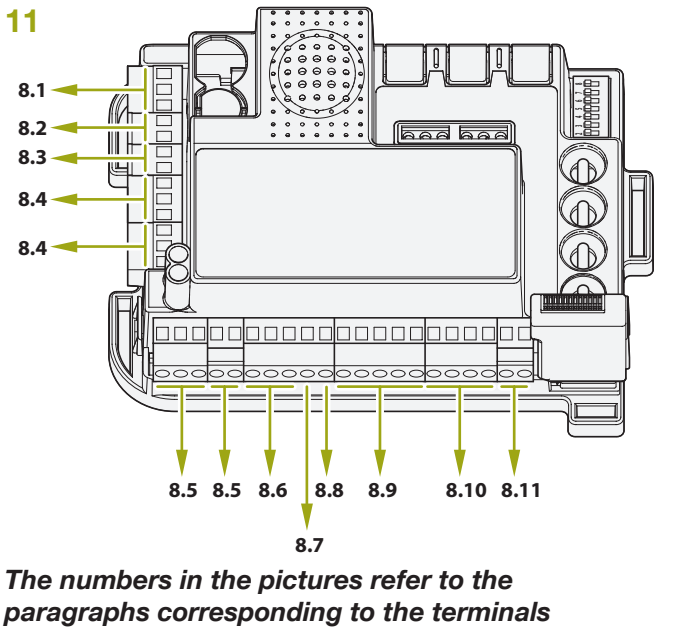

- with the **gate closed** they lock the opening commands.
- with the **gate open** they have no effect.

Figures 11a, 11b and 11c show examples of King Gates “Viky30” photocell installations.

- ⚠ **If multiple devices are connected on this contact, they must be series connected (see Fig. 11c).**
- ⚠ **If one or more photocell pairs are connected, the receivers must be alternated (see Fig. 11c).**

11a

Connection of the TX transmitter

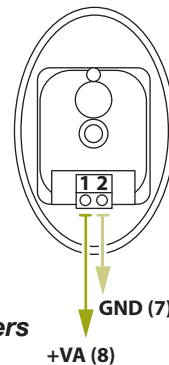

The numbers in the picture between brackets refer to the terminal numbers indicated in Paragraph 2.4

“PHO2” OPENING OR OPENING/CLOSING PHASE SAFETY DEVICES

It is possible to connect devices (e.g. photocells or edges) with normally closed (NC) contact to the “PHO2” input (terminal 6-7). To ensure correct operation of the accessories, eliminate the standard supplied connection.

These devices are actuated while the gate is moving, according to the setting of DIP5 (see par. 3.1).

DIP5 IN ON (funzionamento come fotocellule):

- in **closing phase** they continue the movement as soon the device has been cleared
- in **opening phase** they continue the movement as soon the device has been cleared
- if the **access is closed** they inhibit the opening commands.
- if the **access is open** they inhibit the closing commands.

DIP5 set to OFF (operation as opening edge):

- during the **closing phase** they have no effect
- during the **opening phase** they re-close the gate fully

11b

Connection of the RX receiver Viky30

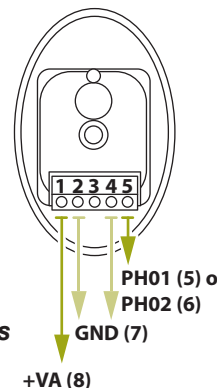

The numbers in the picture between brackets refer to the terminal numbers indicated in Paragraph 2.4

11c

Connection of multiple receiver pairs Viky30

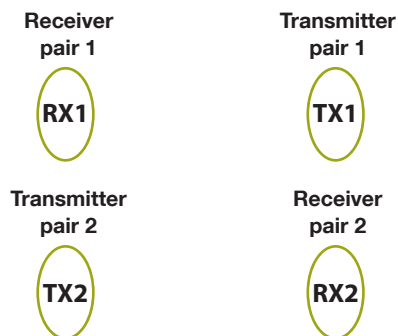
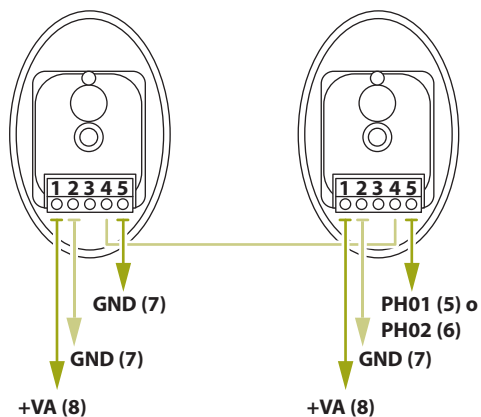

The numbers in the picture between brackets refer to the terminal numbers indicated in Paragraph 2.4

8.7 - 24VDC accessories' power supply

DEDICATED TERMINALS: 7-8 (see Paragraph 2.4).

With the control unit powered, these terminals provide a nominal voltage of 24VDC, max. 250mA, and can be used for external accessories such as, for example, photocells or radio receivers

8.8 - Gate open pilot light

DEDICATED TERMINALS: 7-9 (see Paragraph 2.4).

If the photo-test—which is deactivated by default (see Paragraph 14.1)—is not used, it is possible to connect a gate status pilot light to the “GSI” input (terminal 9). This light will signal the gate’s position, specifically:

gate closed: light off

gate open: light turned on in fixed mode

gate opening: light flashes

gate closing: light flashes fast

⚠ The led must be powered with 24VDC, max 3W.

8.9 - Limit switches

DEDICATED TERMINALS:

sliding = 10-11-12 (see Paragraph 2.4).

swinging = 10-11-12-13-14 (see Paragraph 2.4).

The limit switch inputs are used for connecting the micro-switches with NC clean contacts that open the contact when the gate leaf reaches the limits of the opening and closing path. In the sliding gate model, the limit switches are supplied wired and phased (in the sense of the opening and closing direction) with the motor connections.

In the swinging gate versions, they are not used (they must not be bridged in this case). If used in the installation, make sure the microswitches are connected to NC outputs and synchronised with the motor.

8.10 - Wired commands

DEDICATED TERMINALS: 15-16-17-18 (see Paragraph 2.4).

The inputs for the start, stop and pedestrian opening wired commands can be customised to open, stop and close (Paragraph 14.1).

Moreover, they can be locked to prevent tampering with the system (Paragraph 15.2).

START CONTACT

The “START” input (terminals 15-16) can be used to connect normally open clean contacts (present, for example, in selectors or buttons) for executing commands that pilot the automation, and settable through dip-switch 3 – see Paragraph 3.1 per eseguire i comandi che pilotano l'automazione, impostabili con il dip3, vedi paragrafo 3.1.

⚠ COMPANY FUNCTION: if, with the automation closed, the START contact is pressed and held closed (for example, through a timer-controlled or bistable relay), the control unit opens the gate and the automation does not accept closing commands (neither automatic nor wired) until the contact is reopened.

In this mode, dip-switch 3 STEP is normally put to OFF and dip-switch 4 AUTO to ON, to ensure that the gate never stops during the opening phase.

⚠ If multiple START contacts are connected, connect the contacts in parallel.

PEDESTRIAN CONTACT (terminals 16-18)

The pedestrian function consists of a partial opening (or full opening, depending on the installer’s preferences) of the gate leaf driven by “MOTOR1”.

To customise the opening width, the pedestrian programming sequence must be carried out (see Paragraph 5.2).

This opening can be controlled via radio, by programming the transmitter (see Paragraph 4.2), and/or via wire by connecting the latter to the “PED” input (terminals 16-18) of the normally open contacts (present, for example, in selectors and buttons).

STOP CONTACT

The “STOP” input (terminals 16-17) can be used for connecting normally closed contacts (normally present in buttons), to immediately lock all the system’s movements.

To restore the normal operating mode, the stop contact must be re-closed.

8.11 - Antenna

DEDICATED TERMINALS: 19-20 (see Paragraph 2.4)

The antenna is used for enhancing the reception of signals of the radio transmitters. The control unit has, by default, a wire that functions as an antenna already connected to the PCB. An external antenna (present, for example, in the “Idea Plus” warning light range) can be connected to terminals 1 and 2 of the control unit.

⚠ If an external antenna is connected, the series connected wire must be disconnected.

9. Troubleshooting

	Problem	Symptoms / Causes	Solution
9a	The control unit LEDs are turned off	Mains power shortage	Check for the presence of input mains voltage – see Paragraph 2.2 / 2.3
		The fuses are damaged. Before replacing them, disconnect the mains electricity and verify that there are no short-circuits in the connections	Replace the fuses (see Paragraph 2.3). If the fuses get damaged again, before replacing them disconnect all the cables and verify the integrity of the PCB
9b	The control unit does not enter the programming sequence	When the button for accessing a programming sequence is pressed, all the LEDs flash. The control unit protection has been activated	Deactivate the protection – see Paragraph 16.1
9c	The control unit completes the programming sequence, but does not respond to commands in the standard operating mode	Problems with the safety devices, once the programming sequence is completed, the green stop and/or photo LEDs are off	Check that the “PHO1”, “PHO2” and “STOP” contacts are closed.
		Photo-test of safety devices failed. After a command is pressed for a few seconds, the red “error” LED turns on”	Deactivate the photo-test – see Paragraph 14.1.
9d	The control unit causes the automation to start, but the latter does not cover the full path	Obstacle detection problems. If during the manoeuvre the control unit detects power draw peaks, it goes into obstacle present mode.	First of all, verify that the system works in the manual mode. There must not be any points in which the gate leaf tends to stop. Raise the “OBS” trimmer by turning it clockwise (see Paragraph 3.2). If insufficient, increase the “POWER” trimmer setting and reprogram the stroke. If the problem occurs at the final stage of the path, it may be resolved by eliminating or minimising the slowdown points (see Paragraph 5.3))
		Intervention of the safety devices. Check that the green “photo” and “stop” LEDs remain lit throughout the entire manoeuvre. If there are multiple photocell pairs, these may signal false obstacles	Try bridging the “PHO1”, “PHO2” and “STOP” contacts to verify whether the problem can be resolved. Otherwise, connect the photocells with alternating receivers (see image 11C)
9e	The transmitter does not function	When the programming sequence mentioned in Paragraph 4.1 is completed, the red “radio” LED does not flash	Verify the transmitter’s compatibility: the code must be “Stylo4K” or “Stylo2K”. If the transmitter’s LED does not light up clearly, replace the battery
9f	The transmitter has little range	The transmitter’s range varies in relation to the environmental conditions	Replace the transmitter’s battery. Should this not be sufficient, the control unit is configured for connecting external antennas. See Paragraph 8.11
9g	The control unit does not slow down the gate	If the “Power” trimmer is too high, the control unit—in the space set by default through the gate path programming procedure—is unable to detect the change of speed.	Reduce the setting of the POWER trimmer (par. 3.2) and reprogram the stroke; if this is not sufficient, program the deceleration points (par. 5.3) and set a longer deceleration zone.
9h	The control unit functions correctly, but does not accept wired start and pedestrian commands	When the start or ped contacts are closed, the green “start” LED emits brief flashes. The command lock has been activated	Deactivate the pedestrian and start block. See paragraph 15.2.
9i	The control unit does not make the dip-switch or trimmer modifications effective	Once the dip-switch or trimmer positions have been modified, the control unit does not make the modifications effective. The control unit protection has been activated	Deactivate the control unit lock. See Paragraph 16.1
		Once the “power” trimmer, dip-switch 1-2 “motor” or dip-switch 8 “func” positions have been modified, no resulting effects appear on the system	To make the “power” trimmer or dip-switch 1-2 “motor” modifications effective, the basic or advanced path programming must be redone. Should this not be possible, the control unit lock has been activated. See Paragraph 16.1

10. Advanced programming - Index

The control unit is equipped with advanced programming features which are not required for commissioning the system but rather for configuring advanced functions:

BACKJUMP CONFIGURATION

- Backjump adjustment

AUX OUTPUT PROGRAMMING

- Programming the transmitter button assigned to the AUX output
- Selecting the device connected to the AUX output
- Selecting the AUX output mode
- Selecting the AUX output voltage

ADVANCED SAFETY DEVICE PROGRAMMING

- Phototest activation/deactivation
- Selecting the outputs assigned to the Phototest
- Selecting the type of edge connected to PHO2

WIRED CONTROL CONFIGURATION

- Selecting the automation control mode (start/pedestrian or open/close)
- Wired activation/deactivation of the start and pedestrian block

OTHER FUNCTIONS

- Activation/deactivation of control unit protection
- Resetting the control unit's factory settings
- Energy saving mode

Dati dell'installatore / Installer details

Azienda / Company _____

Timbro / Stamp

Località / Address _____

Provincia / Province _____

Recapito telefonico / Tel. _____

Referente / Contact person _____

Dati del costruttore / Manufacturer's details

KINGGATES

King Gates S.r.l.

Phone +39.0434.737082
info@king-gates.com

Fax +39.0434.786031
www.king-gates.com

