

# SMART 2

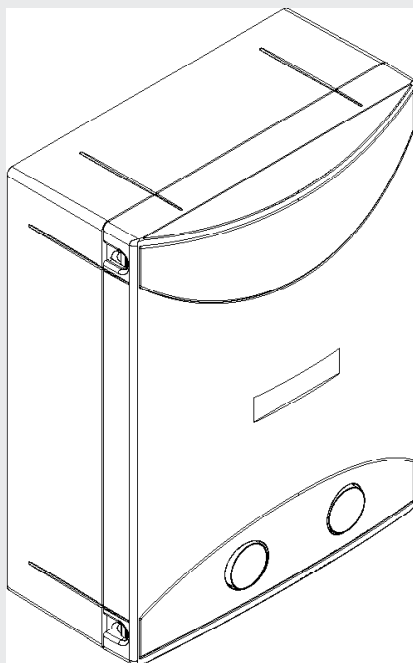

CONTROL PANEL FOR SLIDING OR SECTIONAL DOORS

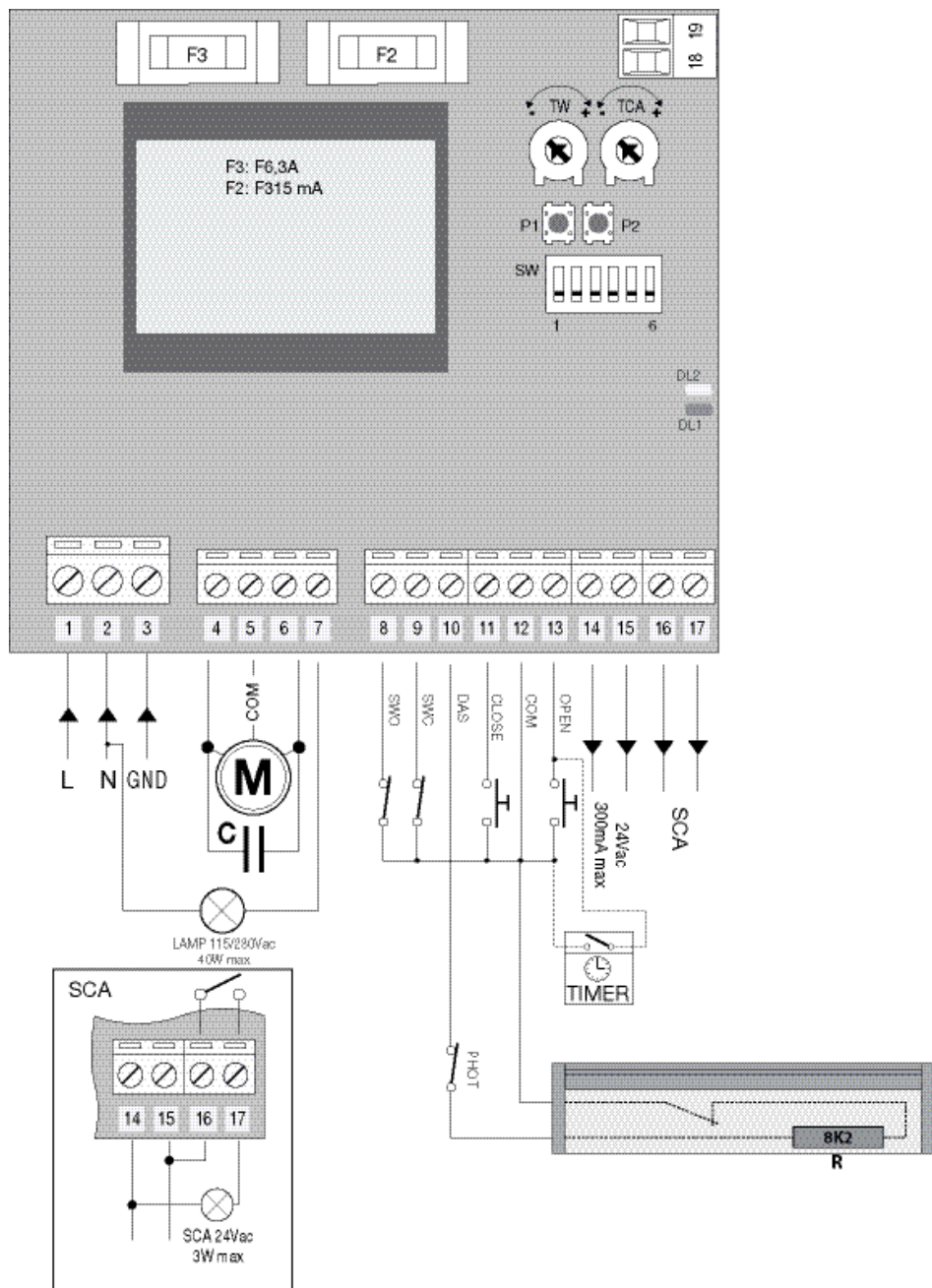



## WARNINGS

This manual has been especially written to be use by qualified fitters.

None of the information provide in this manual can be considered as being of interest for the end users.

Preserve this manual for future needs.

The technician has to furnish all the information related to the step by step function, the manual and the emergency function of the operator, and to deliver the manual to the final user.

- Foresee on the supply net an onnipolar switch or selector with distance of the contacts equal or superior to 3 mms.

Verify that of the electrical system there is an awry differential interrupter and overcurrent protection.

Some typologies of installation require the connection of the shutter to be link at a conductive mass of the ground according to the regulations in force.

The electrical installation and the operating logic must comply with the regulations in force.

The leads fed with different voltages must be physically separate, or they must be suitably insulated with additional insulation of at least 1 mm.

The leads must be secured with an additional fixture near the terminals.

During installation, maintenance and repair, interrupt the power supply before opening the lid to access the electrical parts

Check all the connections again before switching on the power.

The unused N.C. inputs must be bridged.

The descriptions and the present illustrations in this manual are not binding. Leaving the essential characteristics of the product unchanged, the manufacturer reserves himself the right to bring any change of technical, constructive or commercial character without undertaking himself to update the present publication.

## TECHNICAL DATA

Control unit power supply	230 Vac
Power supply	230 Vac 50/60 Hz
Output supply	1 motore230 Vac
Power maximum motor	1000 W
Output supply accessories	24 Vac, 7W max.
Protection level	IP50
Operating temp.	-20°C / +50°C

# SMART 2 control unit with microcontroller

## INPUT/OUTPUT FUNCTIONS

Terminals	Function	Description
1, 2, 3	Power supply	Input, 230VAC 50/60Hz (1-Phase/2-Neutral/GND-Ground connection)
4, 5, 6	Motor	Connection to motor: (MOT-move/COM-Common/MOT-move)
7	LAMP	Output, connection to Flashing light: 230 Vac 40W max.
8	SWO	Input, OPENING limit switch (Normally Closed contact)
9	SWC	Input, CLOSING limit switch (Normally Closed contact)
10	DAS/ PHOT	Safety edge or photocell Input See DIP-SWITCH 3.
11	CLOSE	Input, CLOSE key (N.C. contact)
12	COM	Common, all control inputs.
13	OPEN	Input, OPEN key (N.O. contact). It is possible to connect a timer for opening in time slots. Contact CLOSED:gate open, Contact open:normal operation.
14, 15	24Vac	Output, 24Vac/400mA max accessory power supply.
16,17	SCA	Contact free from voltage, not insulated for the connection of open gate indicator lamp. Open contact with closed door leaf. Flashing light during the door leaf movement. With open door leaf, the contact is closed.
18, 19	Antenna	Not Used

### CHECKING CONNECTIONS:

- 1) Cut off power supply.
- 2) Manually release the door, move it at around half stroke and lock it again.
- 3) Reset power supply.
- 4) Send an opening control signal through the OPEN input.
- 5) The door leaves should open. If not, with stopped motor, it is sufficient to invert the move wires of the motor (MOT/MOT) of the motor and the limit switches (SWO/SWC), if used.
- 6) Adjust Times and operating Logics.

### TRIMMER FUNCTIONS

- TW** It allows the maximum duration of opening and closing.  
It must be preset approx. 4s more with respect to the actual stroke time of the system.  
The adjustment ranges from 3s to 180s maximum.
- TCA** It allows to adjust the automatic closure time.  
The adjustment ranges from 3s to 180s maximum.

## DIP-SWITCH FUNCTION

Dip-Switches	Function	Description
DIP1	TORQUE	To be used for the programming of the torque, as shown hereunder. After presetting the parameters, move to OFF again.
DIP2	TCA	The automatic closure is enabled or disabled. Off: disabled automatic closure. On: enabled automatic closure.
DIP3	DAS/PHOT	The operating mode of input DAS/PHOT is selected: Off: partial reversion (3s) at activation of safety edge. On: total reversion at activation of edge/photocell.
DIP4	SWC MODE	Off: during closure, if SWC is pressed, the motor is blocked. On: during closure, if SWC is pressed, the motor continues its closing movement for further 2 seconds or until the SAFETY EDGE is activated.
DIP5	BLI	Select how OPEN input (13) works: ON: during opening an OPEN command is ignored During closing an OPEN command reverse the motion. OFF: Works according DIP 6 setting
DIP6	OPEN/PP	The operating mode of input 13 (Open) is selected. Available only with DIP 5 OFF On: PP Operation: OPEN > STOP > CLOSE > STOP>. Off: OPEN operation always.

## SERVICE MAN MODE

With all DIPs on ON, the control unit switches to SERVICE MAN mode.

The SWO and SWC inputs are deactivated.

The OPEN/CLOSE push-buttons must be kept pressed during operation. The opening of the STOP input stops the motor.

## ADJUSTMENT OF THE TORQUE (DIP1:ON)

When DIP1 is moved to ON, the board indicates that the torque has been applied during a number of flashes (from 1 to 4) of the DL2 green LED, followed by a 3-s interval.

The max torque is indicated with DL2 green LED with fixed light.

To increase the torque, press P1. The DL2 LED changes the number of flashes to indicate the selected torque value.

Once the desired torque is selected, move DIP 1 to OFF to memorise this presetting.

Note: with actuators for rolling shutters, preset torque at the maximum value.

## RADIO SELF-LEARNING (DIP1:OFF/DIP6:ON)

The SMART 2 control unit is equipped with a built-in radio module for the fixed or roll-on code of remote controls, with 433.92MHz frequency.

To use a remote control, it is first necessary to store its code in memory. The memorisation procedure is described hereunder. The device is able to store up to 64 different codes in memory.

By pressing P1, the control unit enters the radio learning phase: DL1 red LED flashes 1 time per second, awaiting the key to be matched to the Step-by-Step/OPEN function (see DIP6);

When the key is stored in memory, exit from the programming mode;

By pressing P1 twice, the control unit enters the radio learning phase: DL1 red LED flashes 2 times per second, awaiting the key to be matched to the CLOSE function;

When the key to be matched is memorised, exit from the programming mode.

If the programming mode must be left without storing any remote control signal, press P1 key until DL1 red LED starts to flash in "power on" mode (see LED diagnostics on page 7).

To reset the memory of the receiver, press and keep P1 and P2 keys pressed for around 10 seconds (during this period of time, both DL1 and DL2 flash rapidly).

After 10 seconds, when the two LEDs are switched on with fixed light, release the push-buttons.

When the LEDs switch back again to the original configuration, the control unit has completed the memory reset.

NOTE:

The transmitters are memorised on an EPROM memory (U2), which can be extracted from the control unit and inserted in a new SMART 2 control unit should a replacement is required.

For safety reasons, the transmitters can be stored in memory during the opening/closing of the motor.

## LED DIAGNOSTICS

The red LED indicates the activation of inputs according to the legend hereunder:

STOP	on with fixed light
DAS/PHOT	rapid flashing
SWO	1 flash with 2-second interval
SWC	2 flashes with 2-second interval
OPEN+CLOSE	3 flashes with 2-second interval

By flashing slowly, the red LED also indicates that the unit is powered.

The green LED indicates the movement direction of the motor and the status of the gate according to the legend hereunder:

OPENING	1 flash with 1-second interval
CLOSING	2 flashes with 1-second interval
Open gate without TCA	on with fixed light