

DESCRIZIONE GENERALE - GENERAL DESCRIPTION - DESCRIPTION GÉNÉRALE ALLGEMEINE BESCHREIBUNG - DESCRIPCIÓN GENERAL - DADOS TÉCNICOS

- I** Il lampeggiante “**NOVO LT 24 Plus**” è un dispositivo di segnalazione luminoso. L’eventuale intermittenza della luce deve essere gestita esternamente.
- EN** The flashing “NOVO LT 24 Plus” is a signaling device.
The flashing light signal must be managed externally.
- F** Le clignotant “**NOVO LT 24 Plus**” est un dispositif de signalisation lumineuse. L’intermittence éventuelle de la lumière doit être gérée extérieurement.
- E** La lampara “**NOVO LT 24 Plus**” es un dispositivo de señalización luminoso. El eventual parpadeo de la luz debe ser gestionado externamente.
- PT** O pirlampo “**NOVO LT 24 Plus**” é um dispositivo de sinalização.
O sinal de luz intermitente deve ser gerido externamente.

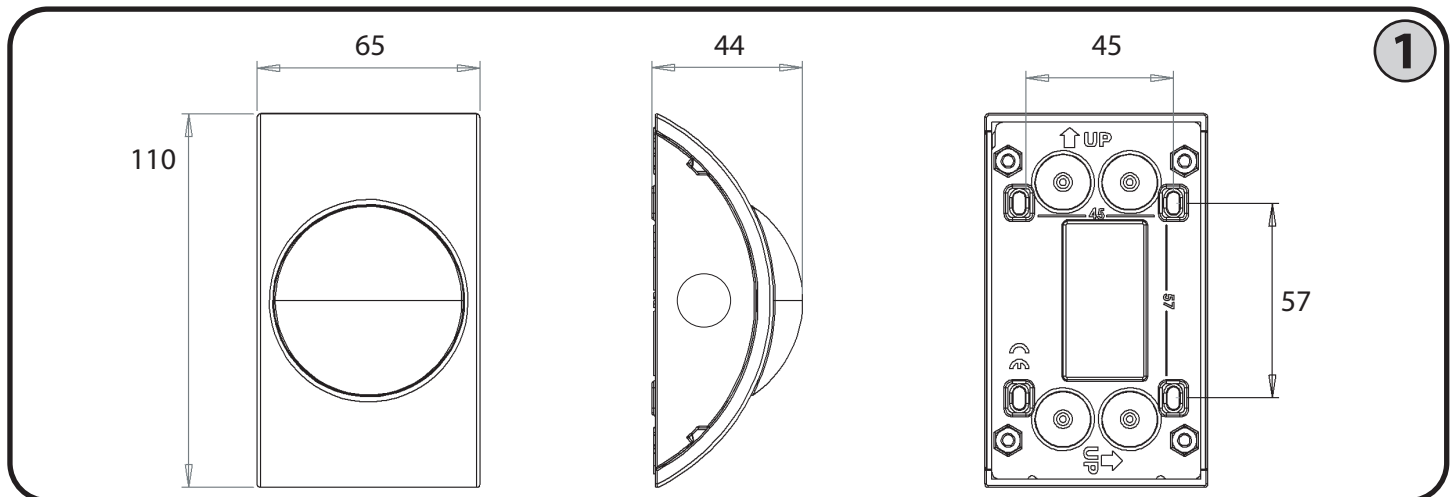

MONTAGGIO - INSTALLATION - ASSEMBLAGE MONTAGE - MONTAJE - INSTALAÇÃO

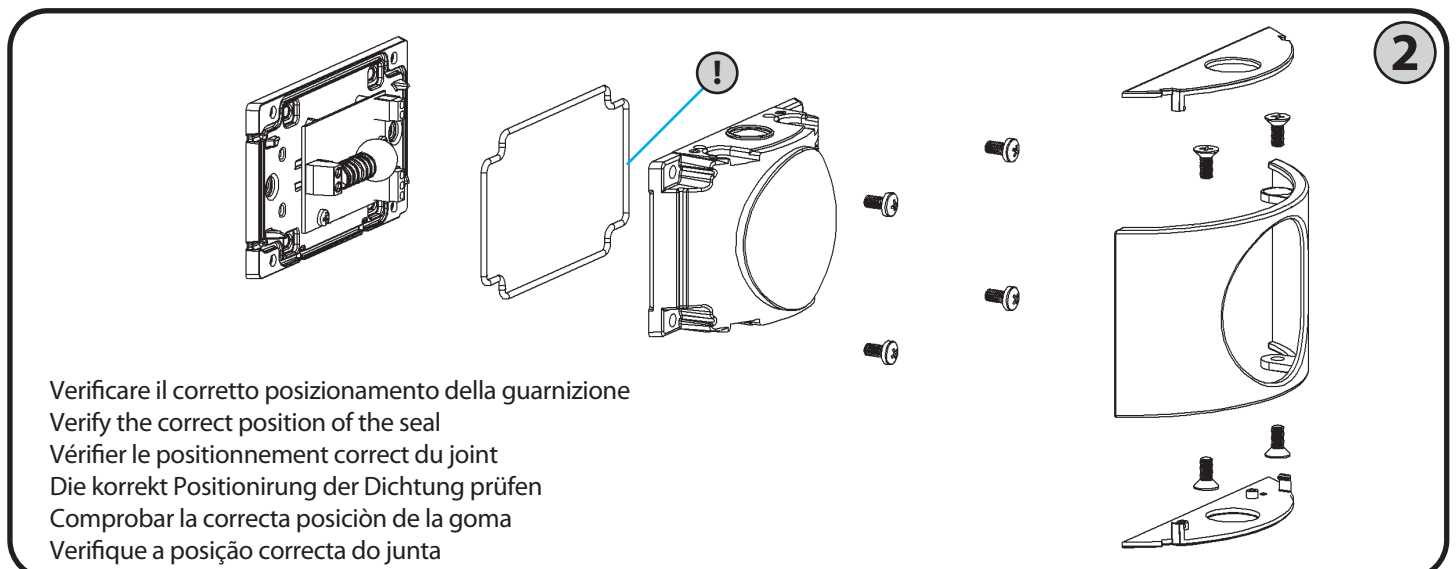

**PASSAGGIO CAVI DALLA BASE - CABLE PASSAGGE FROM THE BOTTOM - PASSAGE CÂBLES PAR LA BASE
KABELDURCHLASS VOM UNTERTEIL - PASAJE DE LOS CABLES DESDE LA BESE - PASSAGEM DE CABO PELO FUNDO**

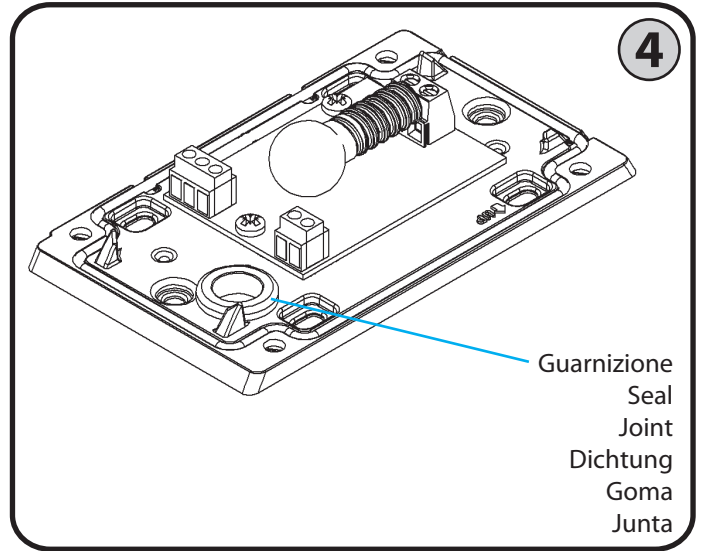
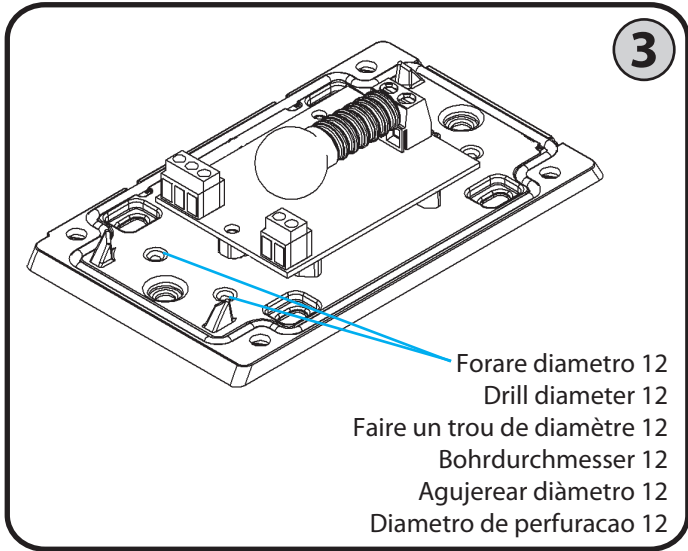

**FISSAGGIO - FIXING - FIXATION
BEFESTIGUNG - FIJACIÓN - FIXAÇÃO**

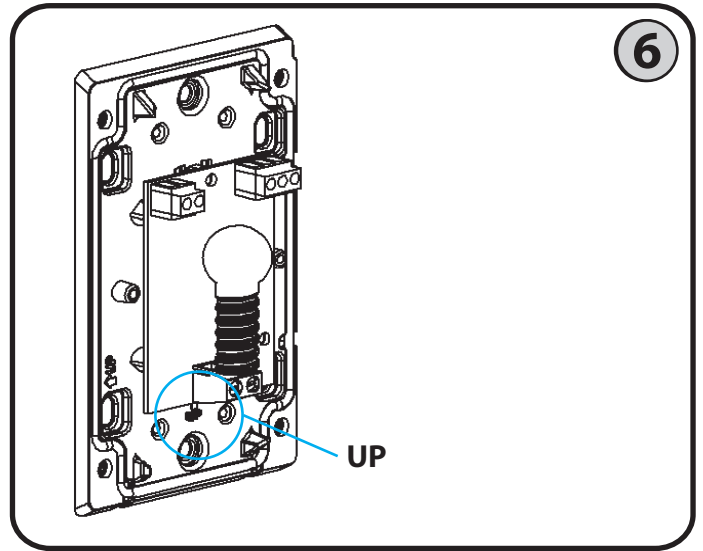
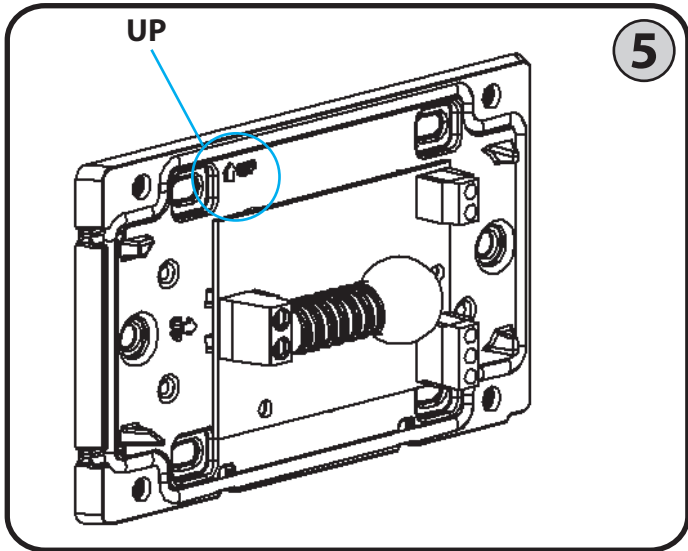

**CABLAGGI - WIRING - RACCORDEMENT
VERKABELUNGEN - CABLEADO - FIAÇÃO**

