

3-PHASE SECTIONAL DOOR AUTOMATION „mPOWER30“

Made in Italy

DESIGNED FOR SECTIONAL DOORS UP TO 30 m²

Italian manufacturer "Gaposa" has spent the last 50 years focusing their attention on designing & manufacturing vertical lift operators. This ensures that the motors are of exceptional quality & sturdiness. All "Gaposa" products are made 100% in Italy. Motor is designed for sectional doors up to 400 kg.

- Power supply - 400 V;
- Direct drive installation on shaft;
- Manual release with declutch device;
- 3phase motor with Digital limits (Kostal encoder);
- Operational sound pressure level <70dB;
- Warranty - 24 months.

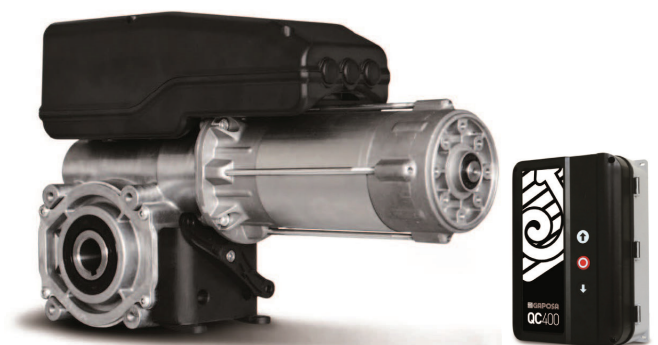

CHARACTERISTICS



CONTROL

mPOWER30 motor can be controlled:

- dead run or impuls by intergrated buttons;
- using remote controls (additional receiver required).

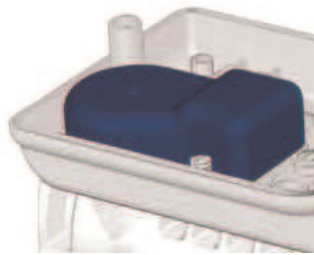

EASY INSTALLATION

Encoder allows to make programming of the door path without setting limits mechanically on the motor.

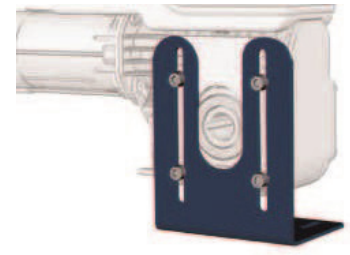

ATTACHMENT

Motor requires low space. To meet any installation requirement, it can be placed either vertically or horizontally by using 4 fixing holes. Mounting bracket included

TECHNICAL SPECIFICATIONS

Code	mPOWER30
Power Supply (V)	400
Asorption (A)	2.20
Max Cycles Per Hour	20
Output Speed (rpm)	21
Holding torque (Nm)	100
Max. door weight (kg)	400
Power (kW)	0.80
Frequency (Hz)	50
Working temperature (C°)	-20°/+60°C
Protection rate (IP)	54
Manufacturer	Gaposa (Italy)
Waranty	2 years